

# Installation / Operation Manual

External Alternator Series 150A for BRP Rotax Aircraft Engines

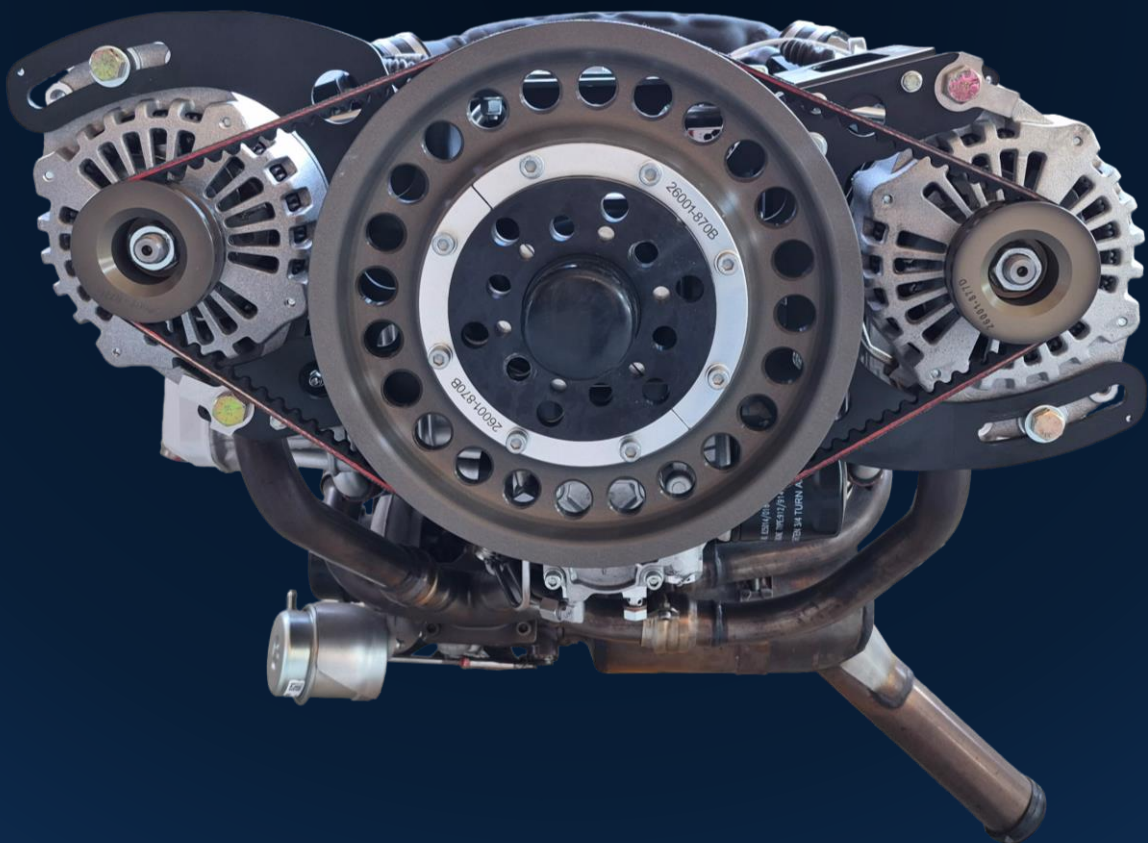

# Contents

- 1. Preface .....2
- 2. System Description .....3
- 3. Technical Specifications Overview .....5
- 4. General Information for Mechanical Installation .....6
  - 4.1 Mounting Layouts .....6
  - 4.2 Propeller Flange .....7
  - 4.3 Rotax Attachment Points 912ULS .....7
  - 4.4 Rotax Attachment Points 912iS .....8
  - 4.5 Rotax Attachment Points 915iS .....9
  - 4.6 Rotax Attachment Points 916iS .....10
  - 4.7 Additional Drawings and Tables .....11
  - 4.8 TBO and TBR Restrictions .....13
- 5. Assembly Instructions for the Individual Kits ..... 14
  - 5.1 Assembly Instructions Ext. Alternator Kit 150A Rotax 912ULS .....14
  - 5.2 Assembly Instructions Ext. Alternator Kit 150A Rotax 912iS .....17
  - 5.3 Assembly Instructions Ext. Alternator Kit 150A Rotax 915iS .....20
  - 5.4 Assembly Instructions Ext. Alternator Kit 150A Rotax 916iS .....23
  - 5.5 Assembly Instructions Ext. Alternator Kit 150A Bank1 Rotax 912iS .....26
  - 5.6 Assembly Instructions Ext. Alternator Kit 150A Bank1 Rotax 915iS .....29
  - 5.7 Assembly Instructions Ext. Alternator Kit 150A Bank1 Rotax 916iS .....32
  - 5.8 Assembly Instructions Ext. Double Alternator Kit 2x 150A Rotax 912iS .....35
  - 5.9 Assembly Instructions Ext. Double Alternator Kit 2x 150A Rotax 915iS .....40
  - 5.10 Assembly Instructions Ext. Double Alternator Kit 2x 150A Rotax 916iS .....44
- 6. Electrical Installation and Operation ..... 48
  - 6.1 Electrical Installation Alternators 150A .....48
  - 6.2 R1224 Regulator Installation .....51
- 7. Belt Tensioning ..... 52
- 8. Performance Charts ..... 53
  - 8.1 Performance Chart Ext. Alternator Kit 150A Rotax 912iS .....53
  - 8.2 Performance Chart Ext. Double Alternator Kit 2x 150A Rotax 912iS .....53
  - 8.3 Performance Chart Ext. Alternator Kit 150A Rotax 915iS .....54
  - 8.4 Performance Chart Ext. Double Alternator Kit 2x 150A Rotax 915iS .....54

# 1. Preface

Thank you for purchasing an RS Flight Systems External Alternator Kit. We are pleased that you have chosen our product and are confident that it will meet all your expectations. In case of questions or problems with the unit, feel free to contact us:

**RS Flight Systems GmbH**  
**Oberer Luessbach 29-31**  
**82335 Berg | Germany**  
**Phone: +49-8178-8681-300**  
**E-Mail: [contact@rs-flight systems.com](mailto:contact@rs-flight systems.com)**

## 2. System Description

The **External Alternator Series 150A** for BRP Rotax Aircraft Engines comprises several kits:

	Description	PN Alternator Kit	PN Mounting Kit	Additional Compatible Engine Types
1	Ext. Alternator Kit 150A Rotax 912ULS	12-001	27005-811	912 and 912S
2	Ext. Alternator Kit 150A Rotax 912iS	10-494	26006-061	914
3	Ext. Alternator Kit 150A Rotax 915iS	10-490	27005-821	
4	Ext. Alternator Kit 150A Rotax 916iS	12-188	27011-721	
5	Ext. Alternator Kit 150A Bank1 Rotax 912iS	12-230	27011-781	914
6	Ext. Alternator Kit 150A Bank1 Rotax 915iS	12-094	27011-711	
7	Ext. Alternator Kit 150A Bank1 Rotax 916iS	12-571	27011-701	
8	Ext. Double Alternator Kit 2x 150A Rotax 912iS	11-239	27005-881	914
9	Ext. Double Alternator Kit 2x 150A Rotax 915iS	10-916	26007-311	
10	Ext. Double Alternator Kit 2x 150A Rotax 916iS	12-192	27011-811	

**Table 2-1: Overview Alternator and Mounting Kits**

**PN Alternator 150A:** 26001-862

**PN Regulator:** 10-358

The **External Alternator Series 150A** can be operated in 14 VDC and 28 VDC mode. The system is fitted with a special transmission ratio to achieve about 50 % of the nominal power at 1800 rpm crankshaft speed (idle), whereas full power is available above 4000 rpm. The high-performance belt drive in combination with the Hartzell alternators leads to a high system efficiency of about 75 %.

The external alternator kits can be operated as single alternator kits, such as the **Ext. Alternator Kit 150A Rotax 915iS** shown in **Figure 2-1**, or as double alternator kits, such as the **Ext. Double Alternator Kit 2x 150A Rotax 915iS** shown in **Figure 2-2**.

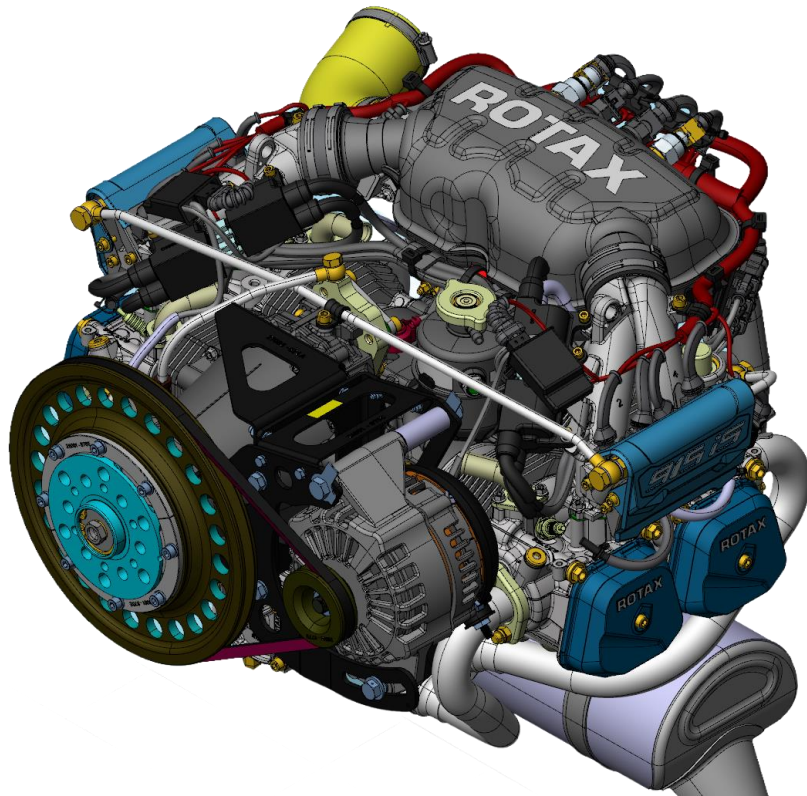

**Figure 2-1: Ext. Alternator Kit 150A Rotax 915iS**

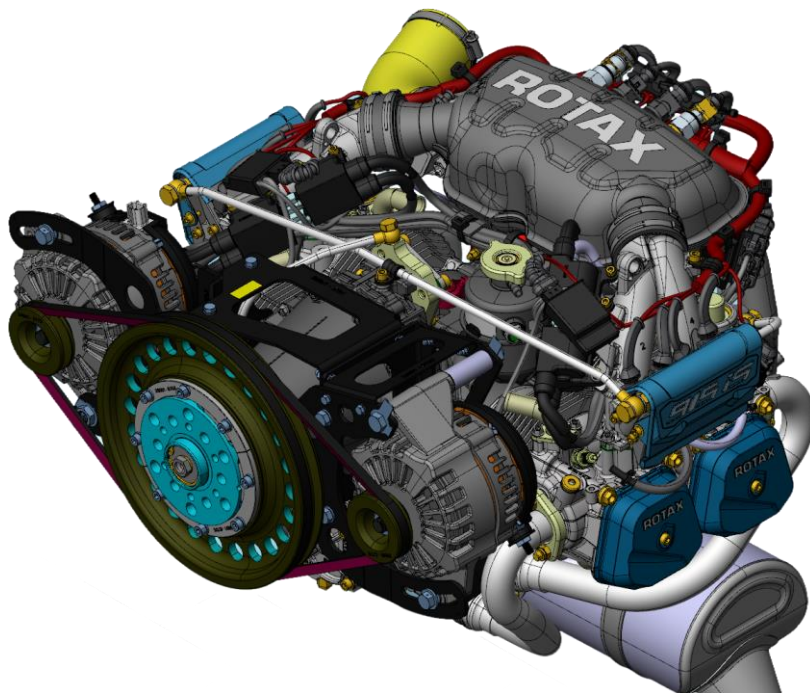

**Figure 2-2: Ext. Double Alternator Kit 2x 150A Rotax 915iS**

### 3. Technical Specifications Overview

The technical specifications of the **External Alternator Series 150A** for BRP Rotax Aircraft Engines are listed in **Table 3-1**.

	Description	PN Alternator Kit	Weight	Current Power	Position
1	Ext. Alternator Kit 150A Rotax 912ULS	12-001	8.7 kg / 19.2 lbs	150 A 4 kW (at 28 VDC)	Bank 2
2	Ext. Alternator Kit 150A Rotax 912iS	10-494	8.8 kg / 19.4 lbs	150 A 4 kW (at 28 VDC)	Bank 2
3	Ext. Alternator Kit 150A Rotax 915iS	10-490	8.7 kg / 19.2 lbs	150 A 4 kW (at 28 VDC)	Bank 2
4	Ext. Alternator Kit 150A Rotax 916iS	12-188	8.9 kg / 19,8 lbs	150 A 4 kW (at 28 VDC)	Bank 2
5	Ext. Alternator Kit 150A Bank1 Rotax 912iS	12-230	8.7 kg / 19.2 lbs	150 A 4 kW (at 28 VDC)	Bank 1
6	Ext. Alternator Kit 150A Bank1 Rotax 915iS	12-094	8.7 kg / 19.2 lbs	150 A 4 kW (at 28 VDC)	Bank 1
7	Ext. Alternator Kit 150A Bank1 Rotax 916iS	12-571	8.7 kg / 19.2 lbs	150 A 4 kW (at 28 VDC)	Bank 1
8	Ext. Double Alternator Kit 2x 150A Rotax 912iS	11-239	17.8 kg / 39.2 lbs	300 A 8 kW (at 28 VDC)	Bank 1 & 2
9	Ext. Double Alternator Kit 2x 150A Rotax 915iS	10-916	17.8 kg / 39.2 lbs	300 A 8 kW (at 28 VDC)	Bank 1 & 2
10	Ext. Double Alternator Kit 2x 150A Rotax 916iS	12-192	18.0 kg / 39.7 lbs	300 A 8 kW (at 28 VDC)	Bank 1 & 2

**Table 3-1: Technical Specifications Alternator Kits**

**Belt tension:** 233 N (equals a force of 25 N when the belt is pushed down 3.63 mm while mounted)

**Temp range:** up to + 240 °F / + 116 °C

## 4. General Information for Mechanical Installation

### 4.1 Mounting Layouts

The **Ext. Alternator Kits 150A** are always mounted to the original Rotax Attachment Points on the Bank 2 side of the engine gearbox (**Figure 4-1**). The **Ext. Alternator Kits 150A Bank1** are intended for installation in combination with the **Ext. Alternator Kits 150A Bank2**, forming the **Ext. Double Alternator Kits 2× 150A**, which are installed on both the Bank 1 and Bank 2 side. (**Figure 4-2**).

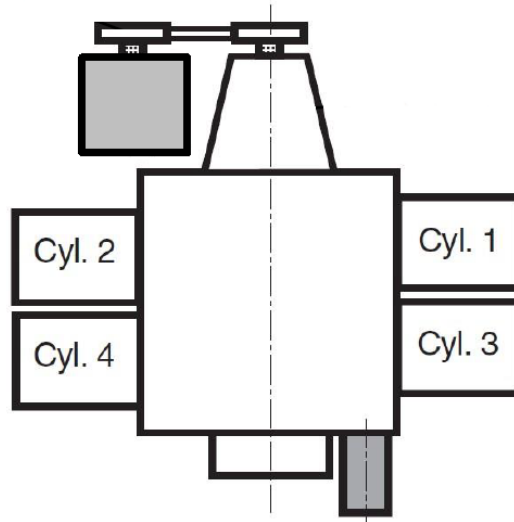

Figure 4-1: Mounting Layout Single Alternator Kit on Bank 2 Side

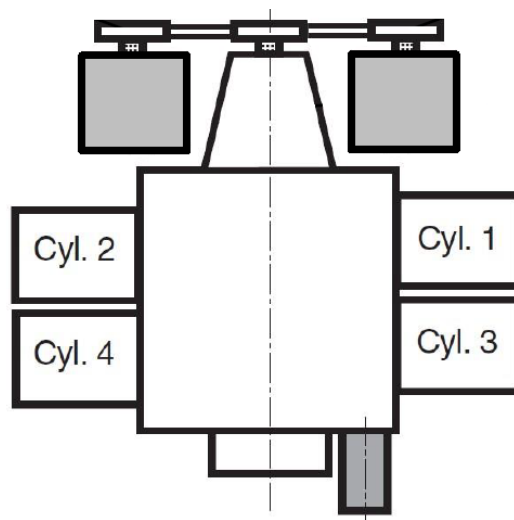

Figure 4-2: Mounting Layout Double Alternator Kit on Bank 1 and Bank 2 Side

## 4.2 Propeller Flange

The Rotax 912, 912S, 912ULS, 912iS, 914 and 915iS engines have a type **A** flange and therefore all corresponding alternator kits contain the same corresponding **Fixing Pulley** (PN 26001-870).

The Rotax 916iS engine, on the other hand, has a type **R** flange and therefore the corresponding alternator kits come with a different fixing pulley, the **Fixing Pulley 916iS** (PN 26007-829). Note that, while the **Ext. Alternator Kits Rotax 916iS** otherwise contain the same components as the **Ext. Alternator Kits Rotax 915iS**, the PN's of the alternator kits are different due to the different propeller flanges and corresponding fixing pulleys.

## 4.3 Rotax Attachment Points 912ULS

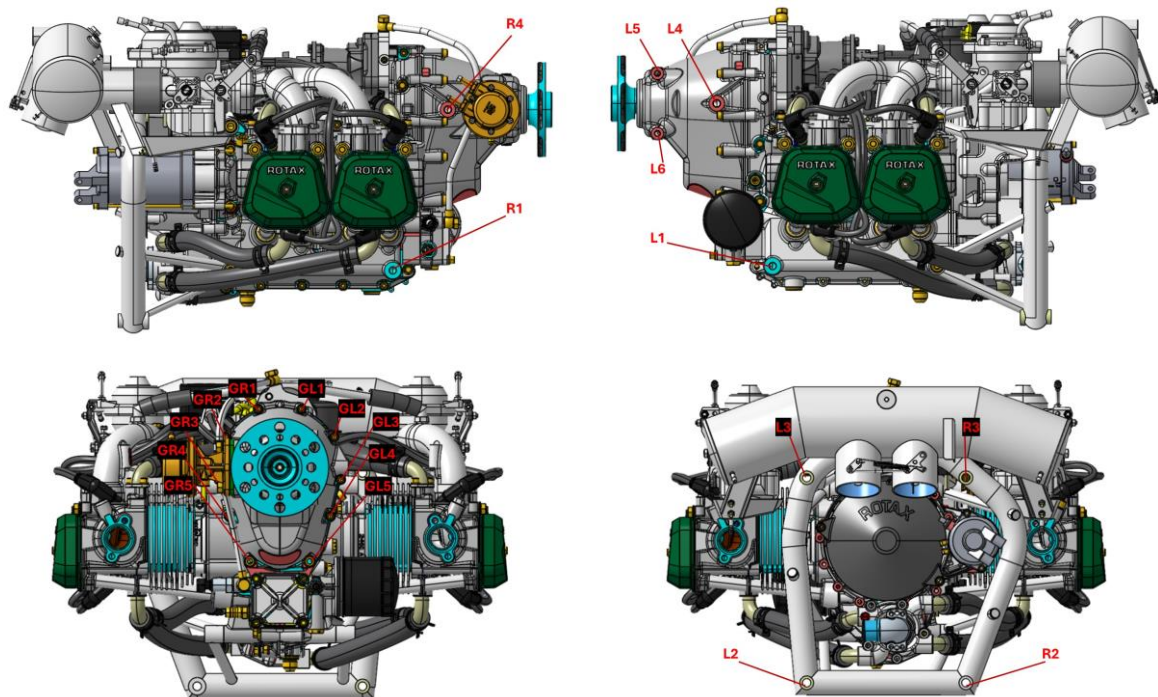

Figure 4-3: Left, Right, Back and Front View Rotax 912ULS Attachment Points

#### 4.4 Rotax Attachment Points 912iS

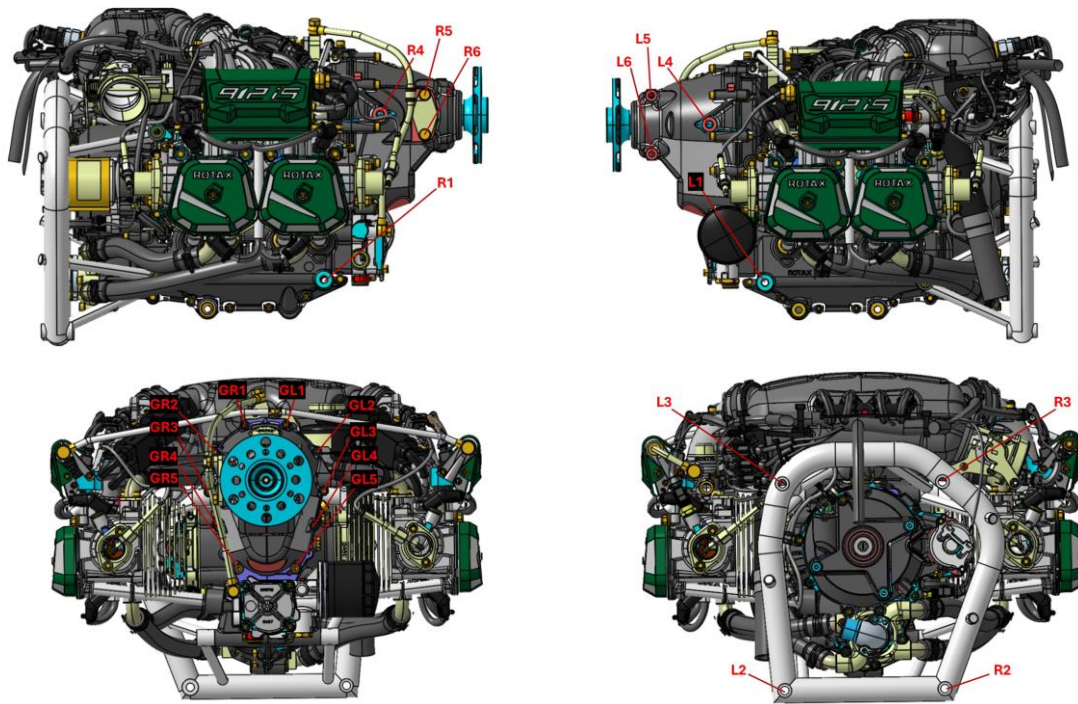

Figure 4-5: Left, Right, Back and Front View Rotax 912iS Attachment Points

## 4.5 Rotax Attachment Points 915iS

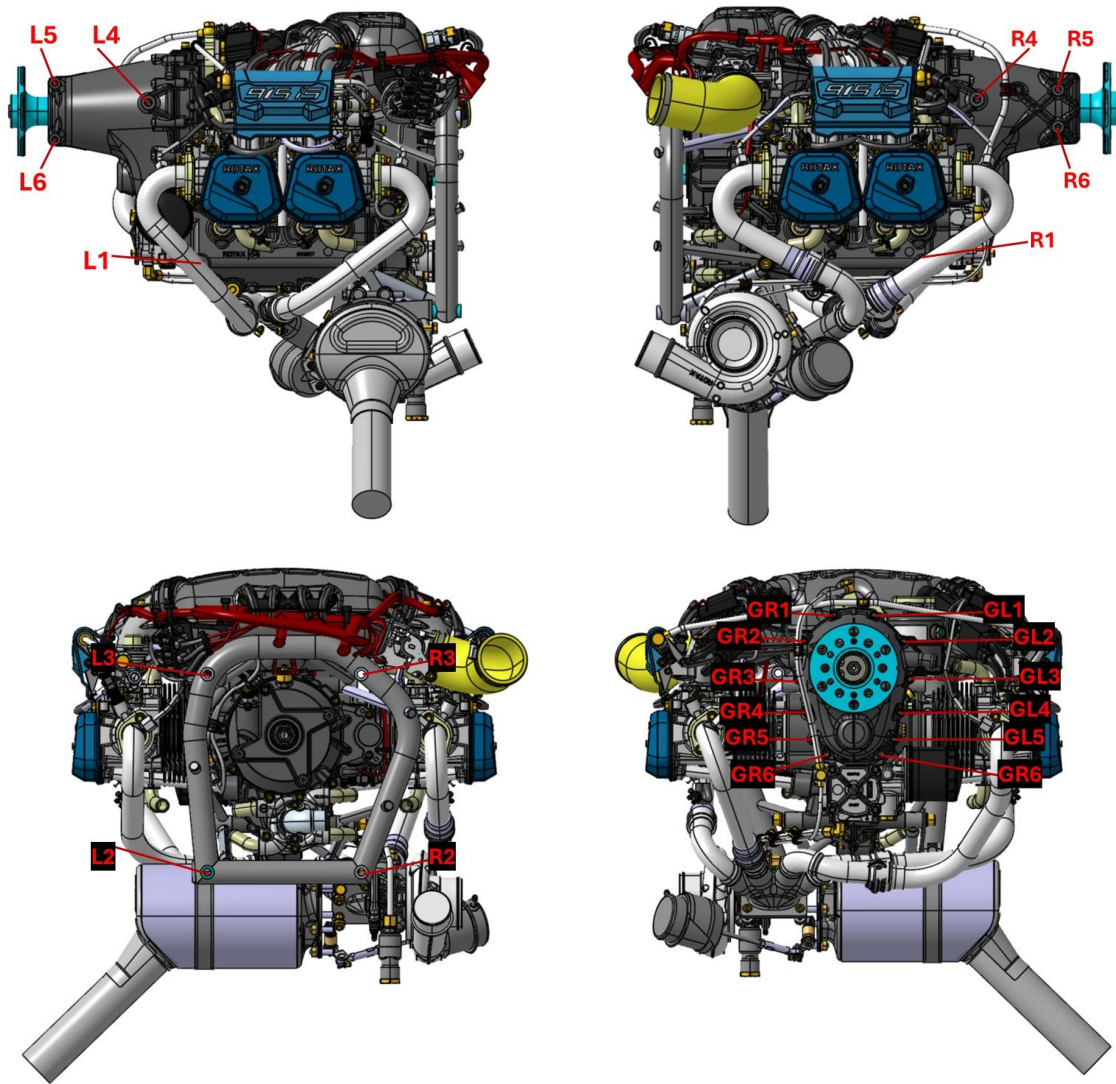

Figure 4-7: Left, Right, Back and Front View Rotax 915iS Attachment Points

## 4.6 Rotax Attachment Points 916iS

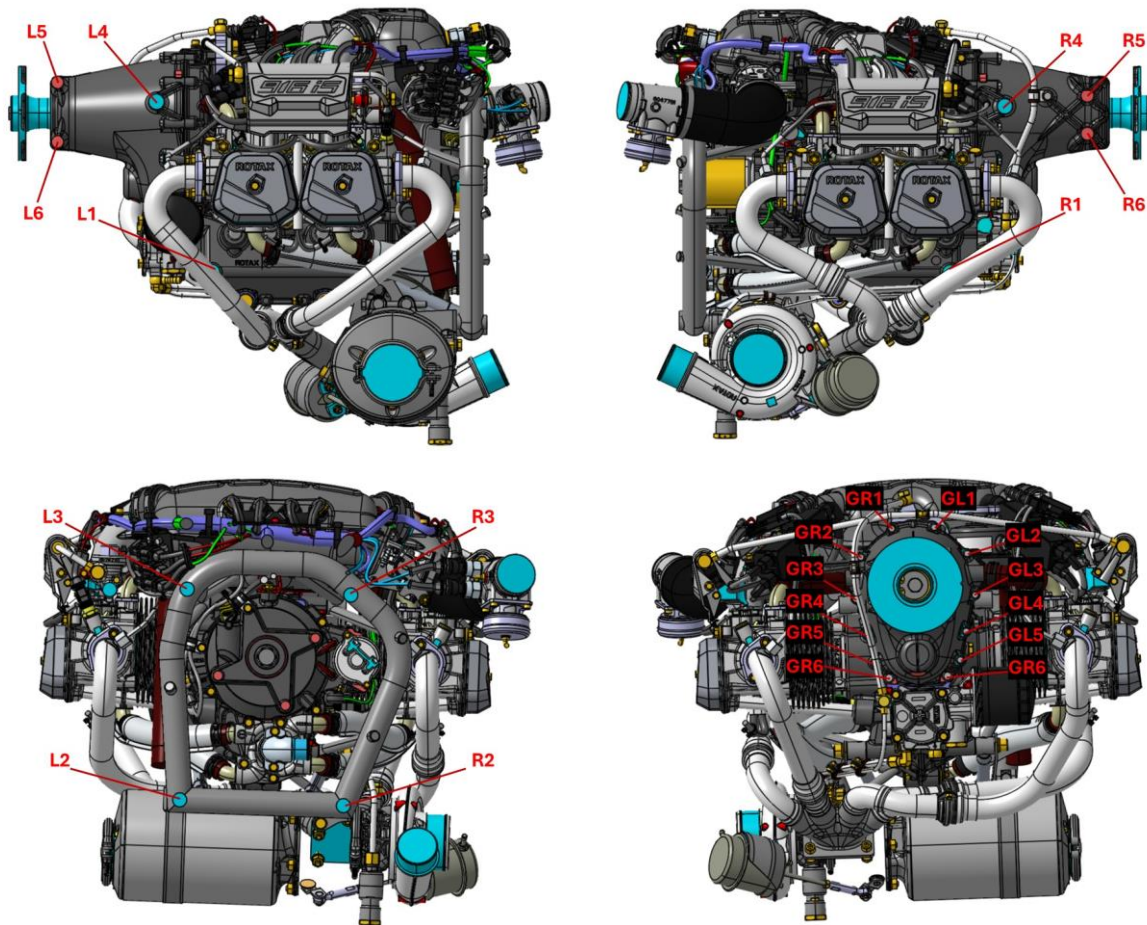

Figure 4-8: Left, Right, Back and Front View Rotax 916iS Attachment Points

## 4.7 Additional Drawings and Tables

Bolt Type	Torque
All M6 bolts into aluminium	5.9 Nm / 4.3 lbft
All M6 bolts into a nut	7.7 Nm / 5.7 lbft
All M8 bolts into a nut	25 Nm / 18.4 lbft
All UNC 3/8" bolts	40.0 Nm / 29.5 lbft
All UNF 7/16" bolts	65.0 Nm / 47.9 lbft

**Table 4-1: Torque Specifications**

Note: for all bolts mounted to the Rotax gearbox / engine check the Rotax engine manual for torque specifications.

For all bolts mounted to the alternator check the Hartzell manual for torque specifications.

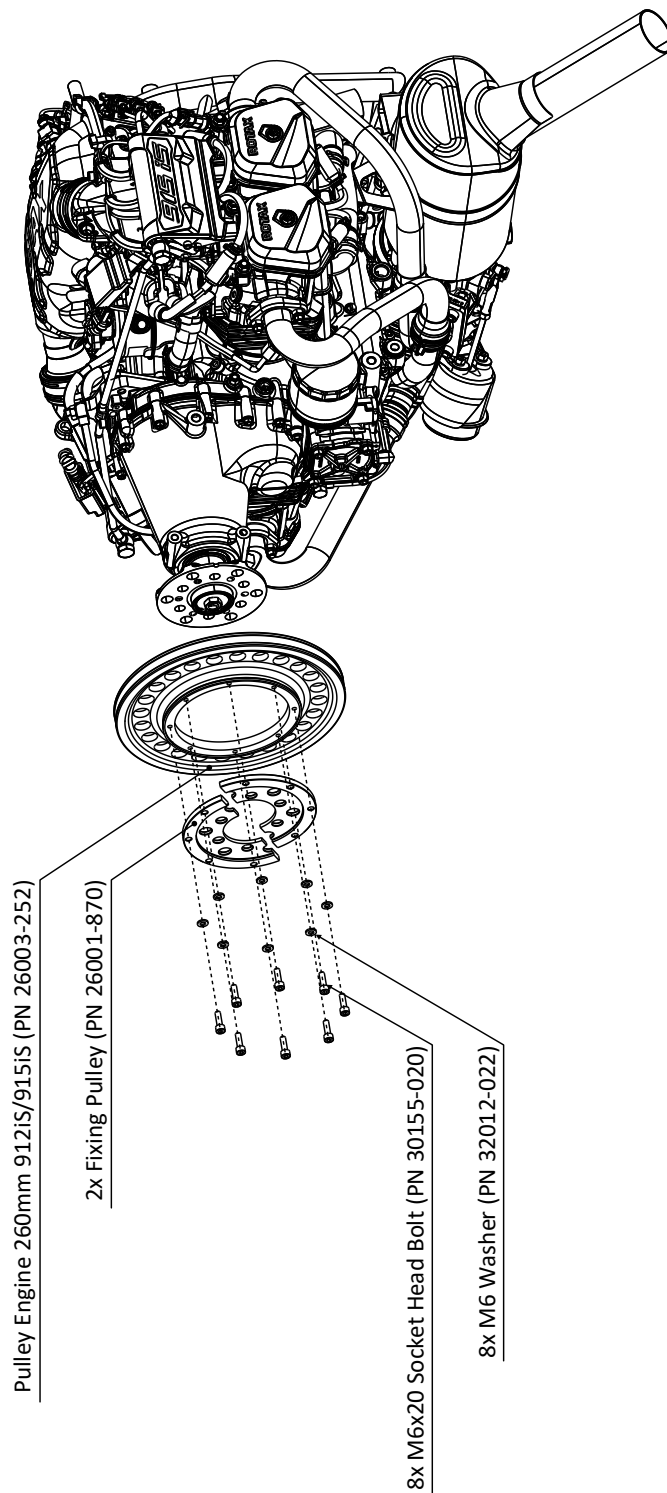

**Figure 4-9: Installation Pulley Engine Ext. Alternator Kit 150A Rotax 915iS**

**Note:** The pulley engine is placed behind the propeller flange and the fixing pulleys between the pulley engine and the propeller flange. **Figure 4-9** shows an exemplary exploded view of the pulley engine installation of the **Ext. Alternator Kit 150A Rotax 915iS**, which is representative of all other alternator kits.

## 4.8 TBO and TBR Restrictions

There is no time between overhaul (TBO) or lifetime (TBR) restriction on the alternator and regulator. During the 100 h Rotax engine check, a visual inspection must be conducted.

The **V-Belt XPZ 962** (PN 26003-253) has a lifetime of 1000 h (TBR). The tension must be checked every 100 h.

## 5. Assembly Instructions for the Individual Kits

### 5.1 Assembly Instructions Ext. Alternator Kit 150A Rotax 912ULS

**PN Alternator Kit:** 12-001  
**PN Mounting Kit:** 27005-811

1. Mount the **Frame Bracket ALT FLX/ES 912ULS** (PN 27005-817) to the Rotax Attachment Points **GL1** and **GL2** with the pre-installed bolts. Do not tighten the bolts yet.
2. Mount the **Frame Flange ALT FLX 912ULS** (PN 27005-815) to the Rotax Attachment Points **L5** and **L6** with 2x **M8x20 Hexagon Bolt** (PN 27011-729) and 2x **M8 Washer** (PN 32010-008). Do not tighten the bolts yet.
3. Mount the **Frame Strut ALT FLX 912ULS** (PN 27005-816) to the Rotax Attachment Point **L4** with 1x **M10x20 Hexagon Bolt** (PN 27011-731) and 1x **M10 Washer** (PN 32010-010). Do not tighten the bolt yet.
4. Connect the **Frame Flange ALT FLX 912ULS** (PN 27005-815) and the **Frame Strut ALT FLX 912ULS** (PN 27005-816) with 3x **M6x20 Hexagon Bolt** (PN 27007-371), 6x **M6 Washer** (PN 32012-022) and 3x **M6 Stop Nut** (PN 27011-723). Do not tighten the bolts yet.
5. Connect the **Frame Bracket ALT FLX/ES 912ULS** (PN 27005-817) and the **Frame Strut ALT FLX 912ULS** (PN 27005-816) with 2x **M6x20 Hexagon Bolt** (PN 27007-371), 4x **M6 Washer** (PN 32012-022) and 2x **M6 Stop Nut** (PN 27011-723). Do not tighten the bolts yet.
6. Mount the **Frame Gusset Plate ALT FLX 912iS/ULS** (PN 26006-078) between the **Frame Flange ALT FLX 912ULS** (PN 27005-815) and the **Frame Strut ALT FLX 912ULS** (PN 27005-816) with 4x **M5x16 Hexagon Bolt** (PN 30004-103), 8x **M5 Washer** (PN 32010-005) and 4x **M5 Stop Nut** (PN 27011-724).
7. Tighten all bolts from steps 1-6 and torque them as specified in **Table 4-1**. Secure the **M10x20 Hexagon Bolt** (PN 27011-731) against the **Frame Strut ALT FLX 912ULS** (PN 27005-816) with safety wire. Secure the 2x **M8x20 Hexagon Bolt** (PN 27011-729) against each other with safety wire.
8. Place the **Pulley Engine 260mm 912 ULS** (PN 27005-813) behind the propeller flange. Place the 2x **Fixing Pulley** (PN 26001-870) between the **Pulley Engine 260mm 912 ULS** (PN 27005-813) and the propeller flange. The fixing pulleys can be temporarily secured with 2x M10 bolts and 2x M10 nuts (not included) until the propeller is installed.
9. Mount the **Pulley Engine 260mm 912ULS** (PN 27005-813) on the 2x **Fixing Pulley** (PN 26001-870) with 8x **M6x20 Socket Head Bolt** (PN 30115-020) and 8x **M6 Washer** (PN 32012-022). Apply Loctite 243 on all 8x **M6x20 Socket Head Bolt** (PN 30115-020).
10. Apply battery terminal grease on all connections between the alternator and the bearings.
11. Mount the **Alternator ALT FLX** (PN 26001-862) between the **Frame Flange ALT FLX 912ULS** (PN 27005-815) and the **Frame Strut ALT FLX 912ULS** (PN 27005-816) by inserting 1x **UNF 7/16"-20 x 4" Hexagon Bolt** (PN 27007-507) with 1x **UNF 7/16"-20 Flat Nut** (PN 27007-506) and 2x **M12 Locking Plates** (PN 32200-012) through the pivot hole of the alternator. Do not tighten the bolt yet.

12. Adjust the position in x-direction between the **Alternator ALT FLX** (PN 26001-862) and the frames using the **Shim Set Alternator** (PN 12-542). Ensure that the **Pulley Engine 260mm 912ULS** (PN 27005-813) and the pre-mounted **Pulley ALT FLX 912iS/ULS** (PN 26006-065) are in the same plane for proper belt alignment. The assembly needs to fit tight between the **Frame Flange ALT FLX 912ULS** (PN 27005-815) and the **Frame Strut ALT FLX 912ULS** (PN 27005-816).
13. Mount the **V-Belt XPZ 962** (PN 26003-253) on the **Pulley Engine 260mm 912ULS** (PN 27005-813) and the pre-mounted **Pulley ALT FLX 912iS/ULS** (PN 26006-065).
14. Mount the propeller as described in the propeller manual. The propeller bolts must be inserted through both the Rotax propeller shaft holes and the **Fixing Pulley** (PN 26001-870) mounting holes.
15. Move the **Alternator ALT FLX** (PN 26001-862) to tense the belt. Fix the position by inserting 1x **UNC 3/8"-16 x 3/4" Hexagon Bolt** (PN 27011-699) with 1x **M10 Washer** (PN 32010-010) through the slot of the **Frame Flange ALT FLX 912ULS** (PN 27005-815) into the adjusting hole of the alternator. The belt will soften during the first few runs and needs to be retightened. Use the **Shim Set Alternator** (PN 12-542) to align the alternator to the frames.
16. Tighten and torque the **UNC 3/8"-16 x 3/4" Hexagon Bolt** (PN 27011-699) as specified in **Table 4-1**. Secure it against the **Frame Flange ALT FLX 912ULS** (PN 27005-815) with safety wire.
17. Tighten and torque the **UNF 7/16"-20 x 4" Hexagon Bolt** (PN 27007-507) as specified in **Table 4-1**. Bend the edges of the **M12 Locking Plates** (PN 32200-012) according to usual procedure to secure them.
18. Thoroughly check the complete installation.

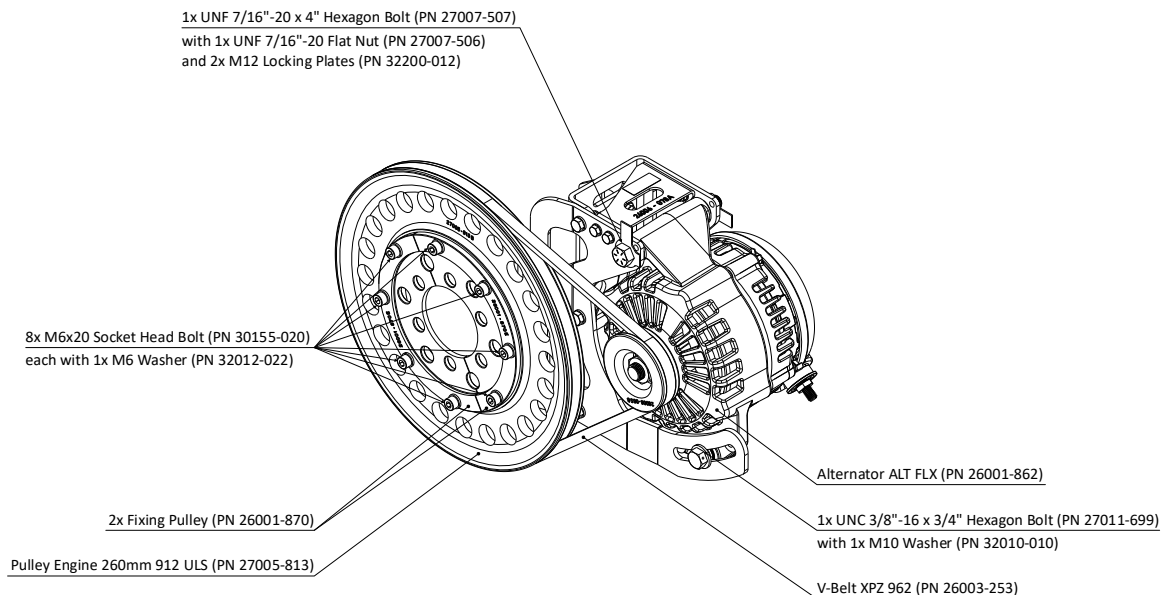

**Figure 5-1: Isometric View Ext. Alternator Kit 150A Rotax 912ULS**

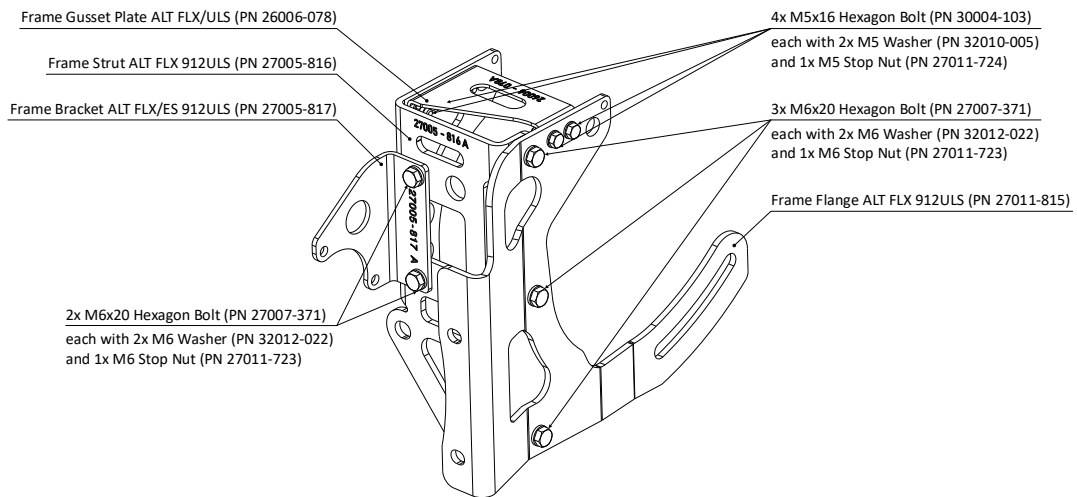

**Figure 5-2: Isometric View Ext. Alternator Kit 150A Rotax 912ULS Frames**

## 5.2 Assembly Instructions Ext. Alternator Kit 150A Rotax 912iS

**PN Alternator Kit:** 10-494

**PN Mounting Kit:** 26006-061

1. Mount the **Frame Bracket ALT FLX/ES 912iS** (PN 26006-068) to the Rotax Attachment Points **GL1** and **GL2** with the pre-installed bolts. Do not tighten the bolts yet.
2. Mount the **Frame Flange ALT FLX 912iS** (PN 26006-064) to the Rotax Attachment Points **L5** and **L6** with 2x **M8x20 Hexagon Bolt** (PN 27011-729) and 2x **M8 Washer** (PN 32010-008). Do not tighten the bolts yet.
3. Mount the **Frame Strut ALT FLX 912iS** (PN 26006-063) to the Rotax Attachment Point **L4** with 1x **M10x20 Hexagon Bolt** (PN 27011-731) and 1x **M10 Washer** (PN 32010-010). Do not tighten the bolt yet.
4. Connect the **Frame Flange ALT FLX 912iS** (PN 26006-064) and the **Frame Strut ALT FLX 912iS** (PN 26006-063) with 3x **M6x20 Hexagon Bolt** (PN 27007-371), 6x **M6 Washer** (PN 32012-022) and 3x **M6 Stop Nut** (PN 27011-723). Do not tighten the bolts yet.
5. Connect the **Frame Bracket ALT FLX/ES 912iS** (PN 26006-068) and the **Frame Strut ALT FLX 912iS** (PN 26006-063) with 2x **M6x20 Hexagon Bolt** (PN 27007-371), 4x **M6 Washer** (PN 32012-022) and 2x **M6 Stop Nut** (PN 27011-723). Do not tighten the bolts yet.
6. Mount the **Frame Gusset Plate ALT FLX 912iS/ULS** (PN 26006-078) between the **Frame Flange ALT FLX 912iS** (PN 26006-064) and the **Frame Strut ALT FLX 912iS** (PN 26006-063) with 4x **M5x16 Hexagon Bolt** (PN 30004-103), 8x **M5 Washer** (PN 32010-005) and 4x **M5 Stop Nut** (PN 27011-724).
7. Tighten all bolts from steps 1-6 and torque them as specified in **Table 4-1**. Secure the **M10x20 Hexagon Bolt** (PN 27011-731) against the **Frame Strut ALT FLX 912iS** (PN 26006-063) with safety wire. Secure the 2x **M8x20 Hexagon Bolt** (PN 27011-729) against each other with safety wire.
8. Place the **Pulley Engine 260mm 912iS/915iS** (PN 26003-252) behind the propeller flange. Place the 2x **Fixing Pulley** (PN 26001-870) between the **Pulley Engine 260mm 912iS/915iS** (PN 26003-252) and the propeller flange. The fixing pulleys can be temporarily secured with 2x M10 bolts and 2x M10 nuts (not included) until the propeller is installed.
9. Mount the **Pulley Engine 260mm 912iS/915iS** (PN 26003-252) on the 2x **Fixing Pulley** (PN 26001-870) with 8x **M6x20 Socket Head Bolt** (PN 30115-020) and 8x **M6 Washer** (PN 32012-022). Apply Loctite 243 on all 8x **M6x20 Socket Head Bolt** (PN 30115-020).
10. Apply battery terminal grease on all connections between the alternator and the bearings.
11. Mount the **Alternator ALT FLX** (PN 26001-862) between the **Frame Flange ALT FLX 912iS** (PN 26006-064) and the **Frame Strut ALT FLX 912iS** (PN 26006-063) by inserting 1x **UNF 7/16"-20 x 4" Hexagon Bolt** (PN 27007-507) with 1x **UNF 7/16"-20 Flat Nut** (PN 27007-506) and 2x **M12 Locking Plates** (PN 32200-012) through the pivot hole of the alternator. Do not tighten the bolt yet.
12. Adjust the position in x-direction between the **Alternator ALT FLX** (PN 26001-862) and the frames using the **Shim Set Alternator** (PN 12-542). Ensure that the **Pulley Engine 260mm 912iS/915iS** (PN 26003-252) and the pre-mounted **Pulley ALT FLX 912iS/ULS** (PN 26006-065) are in the same plane for proper belt alignment. The assembly needs to fit tight between the

**Frame Flange ALT FLX 912iS** (PN 26006-064) and the **Frame Strut ALT FLX 912iS** (PN 26006-063).

13. Mount the **V-Belt XPZ 962** (PN 26003-253) on the **Pulley Engine 260mm 912iS/915iS** (PN 26003-252) and the pre-mounted **Pulley ALT FLX 912iS/ULS** (PN 26006-065).
14. Mount the propeller as described in the propeller manual. The propeller bolts must be inserted through both the Rotax propeller shaft holes and the **Fixing Pulley** (PN 26001-870) mounting holes.
15. Move the **Alternator ALT FLX** (PN 26001-862) to tense the belt. Fix the position by inserting 1x **UNC 3/8"-16 x 3/4" Hexagon Bolt** (PN 27011-699) with 1x **M10 Washer** (PN 32010-010) through the slot of the **Frame Flange ALT FLX 912iS** (PN 26006-064) into the adjusting hole of the alternator. The belt will soften during the first few runs and needs to be retightened. Use the **Shim Set Alternator** (PN 12-542) to align the alternator to the frames.
16. Tighten and torque the **UNC 3/8"-16 x 3/4" Hexagon Bolt** (PN 27011-699) as specified in **Table 4-1**. Secure it against the **Frame Flange ALT FLX 912iS** (PN 26006-064) with safety wire.
17. Tighten and torque the **UNF 7/16"-20 x 4" Hexagon Bolt** (PN 27007-507) as specified in **Table 4-1**. Bend the edges of the **M12 Locking Plates** (PN 32200-012) according to usual procedure to secure them.
18. Thoroughly check the complete installation.

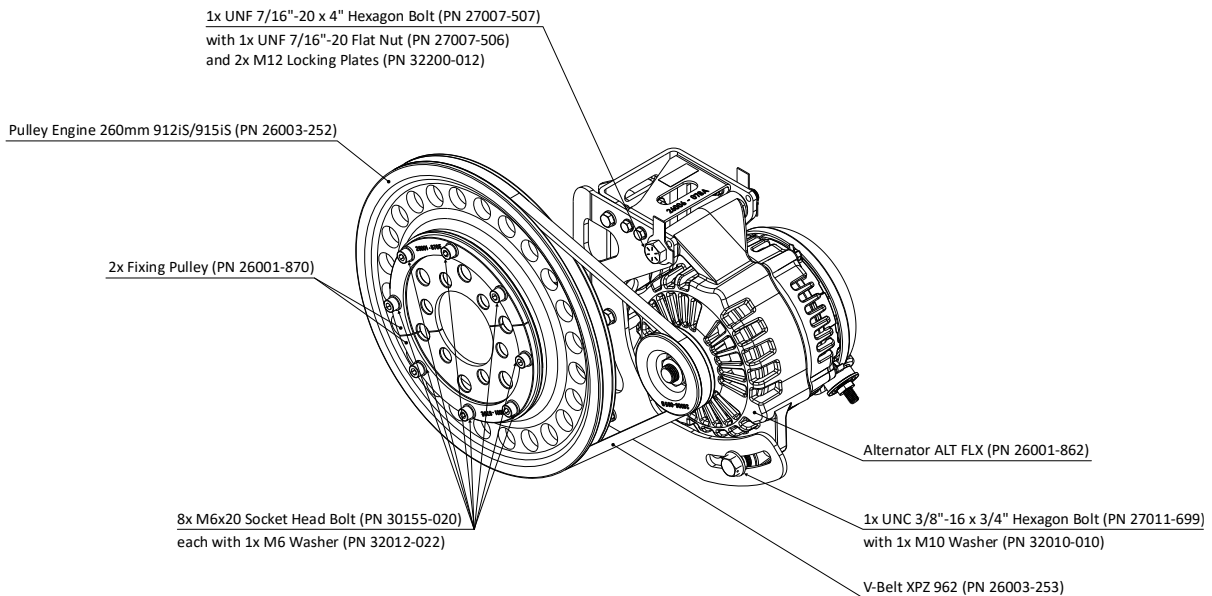

**Figure 5-3: Isometric View Ext. Alternator Kit 150A Rotax 912iS**

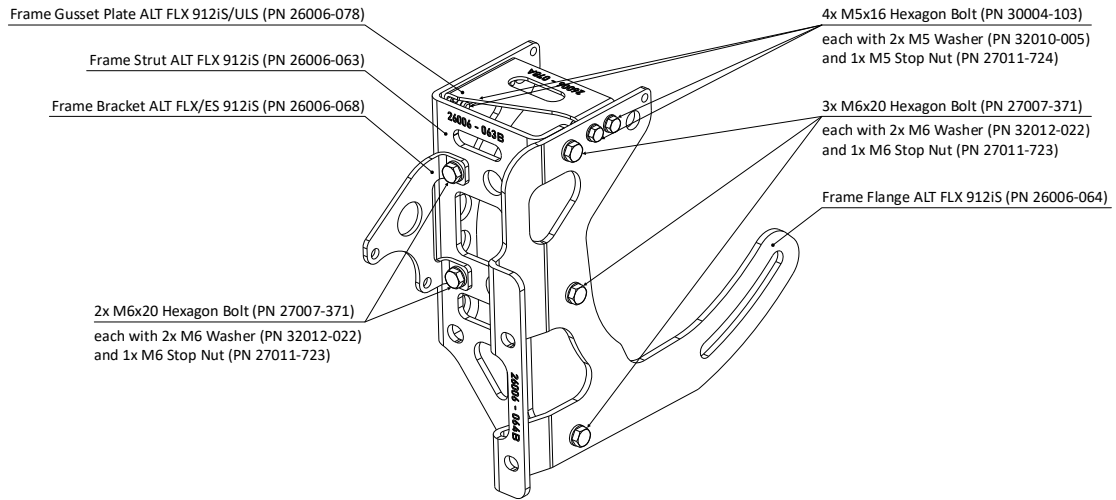

**Figure 5-4: Isometric View Ext. Alternator Kit 150A Rotax 912iS Frames**

### 5.3 Assembly Instructions Ext. Alternator Kit 150A Rotax 915iS

**PN Alternator Kit:** 10-490

**PN Mounting Kit:** 27005-821

1. Mount the **Frame Bracket ALT FLX 915iS** (PN 27005-826) to the Rotax Attachment Points **GR1** and **GL1** with the pre-installed bolts. Do not tighten the bolts yet.
2. Mount the **Frame Flange ALT FLX 915iS** (PN 26007-322) to the Rotax Attachment Points **L5** and **L6** with 2x **M8x20 Hexagon Bolt** (PN 27011-729) and 2x **M8 Washer** (PN 32010-008). Do not tighten the bolts yet.
3. Mount the **Frame Strut ALT FLX 915iS** (PN 26001-872) to the Rotax Attachment Point **L4** with 1x **M10x20 Hexagon Bolt** (PN 27011-731) and 1x **M10 Washer** (PN 32010-010). Do not tighten the bolt yet.
4. Connect the **Frame Flange ALT FLX 915iS** (PN 26007-322) and the **Frame Strut ALT FLX 915iS** (PN 26001-872) with 2x **M8x20 Hexagon Bolt** (PN 27011-728), 4x **M8 Washer** (PN 32010-008) and 2x **M8 Stop Nut** (PN 27011-725). Do not tighten the bolts yet.
5. Connect the **Frame Bracket ALT FLX 915iS** (PN 27005-826) and the **Frame Strut ALT FLX 915iS** (PN 26001-872) with 2x **M6x20 Hexagon Bolt** (PN 27007-371), 4x **M6 Washer** (PN 32012-022) and 2x **M6 Stop Nut** (PN 27011-723). Do not tighten the bolts yet.
6. Mount the **Frame Gusset Plate ALT FLX 915iS** (PN 26001-873) between the **Frame Flange ALT FLX 915iS** (PN 26007-322) and the **Frame Strut ALT FLX 915iS** (PN 26001-872) with 4x **M5x16 Hexagon Bolt** (PN 30004-103), 8x **M5 Washer** (PN 32010-005) and 4x **M5 Stop Nut** (PN 27011-724).
7. Tighten all bolts from steps 1-6 and torque them as specified in **Table 4-1**. Secure the **M10x20 Hexagon Bolt** (PN 27011-731) against the **Frame Strut ALT FLX 915iS** (PN 26001-872) with safety wire. Secure the 2x **M8x20 Hexagon Bolt** (PN 27011-729) against each other with safety wire.
8. Place the **Pulley Engine 260mm 912iS/915iS** (PN 26003-252) behind the propeller flange. Place the 2x **Fixing Pulley** (PN 26001-870) between the **Pulley Engine 260mm 912iS/915iS** (PN 26003-252) and the propeller flange. The fixing pulleys can be temporarily secured with 2x M10 bolts and 2x M10 nuts (not included) until the propeller is installed.
9. Mount the **Pulley Engine 260mm 912iS/915iS** (PN 26003-252) on the 2x **Fixing Pulley** (PN 26001-870) with 8x **M6x20 Socket Head Bolt** (PN 30115-020) and 8x **M6 Washer** (PN 32012-022). Apply Loctite 243 on all 8x **M6x20 Socket Head Bolt** (PN 30115-020).
10. Apply battery terminal grease on all connections between the alternator and the bearings.
11. Mount the **Alternator ALT FLX** (PN 26001-862) between the **Frame Flange ALT FLX 915iS** (PN 26007-322) and the **Frame Strut ALT FLX 915iS** (PN 26001-872) by inserting 1x **UNF 7/16"-20 x 6" Hexagon Bolt** (PN 30006-422) with 1x **UNF 7/16"-20 Nut** (PN 44421-006), the **Distance Tube ALT FLX** (PN 26001-875) and 2x **M12 Locking Plates** (PN 32200-012) through the pivot hole of the alternator. Do not tighten the bolt yet.
12. Adjust the position in x-direction between the **Alternator ALT FLX** (PN 26001-862) and the frames using the **Shim Set Alternator** (PN 12-542). Ensure that the **Pulley Engine 260mm 912iS/915iS** (PN 26003-252) and the pre-mounted **Pulley ALT FLX 915iS** (PN 26001-877) are in

- the same plane for proper belt alignment. The assembly needs to fit tight between the **Frame Flange ALT FLX 915iS** (PN 26007-322) and the **Frame Strut ALT FLX 915iS** (PN 26001-872).
13. Mount the **V-Belt XPZ 962** (PN 26003-253) on the **Pulley Engine 260mm 912iS/915iS** (PN 26003-252) and the pre-mounted **Pulley ALT FLX 915iS** (PN 26001-877).
  14. Mount the propeller as described in the propeller manual. The propeller bolts must be inserted through both the Rotax propeller shaft holes and the **Fixing Pulley** (PN 26001-870) mounting holes.
  15. Move the **Alternator ALT FLX** (PN 26001-862) to tense the belt. Fix the position by inserting 1x **UNC 3/8"-16 x 3/4" Hexagon Bolt** (PN 27011-699) with 1x **M10 Washer** (PN 32010-010) through the slot of the **Frame Flange ALT FLX 915iS** (PN 26007-322) into the adjusting hole of the alternator. The belt will soften during the first few runs and needs to be retightened. Use the **Shim Set Alternator** (PN 12-542) to align the alternator to the frames.
  16. Tighten and torque the **UNC 3/8"-16 x 3/4" Hexagon Bolt** (PN 27011-699) as specified in **Table 4-1**. Secure it against the **Frame Flange ALT FLX 915iS** (PN 26007-322) with safety wire.
  17. Tighten and torque the **UNF 7/16"-20 x 6" Hexagon Bolt** (PN 30006-422) as specified in **Table 4-1**. Bend the edges of the **M12 Locking Plates** (PN 32200-012) according to usual procedure to secure them.
  18. Thoroughly check the complete installation.

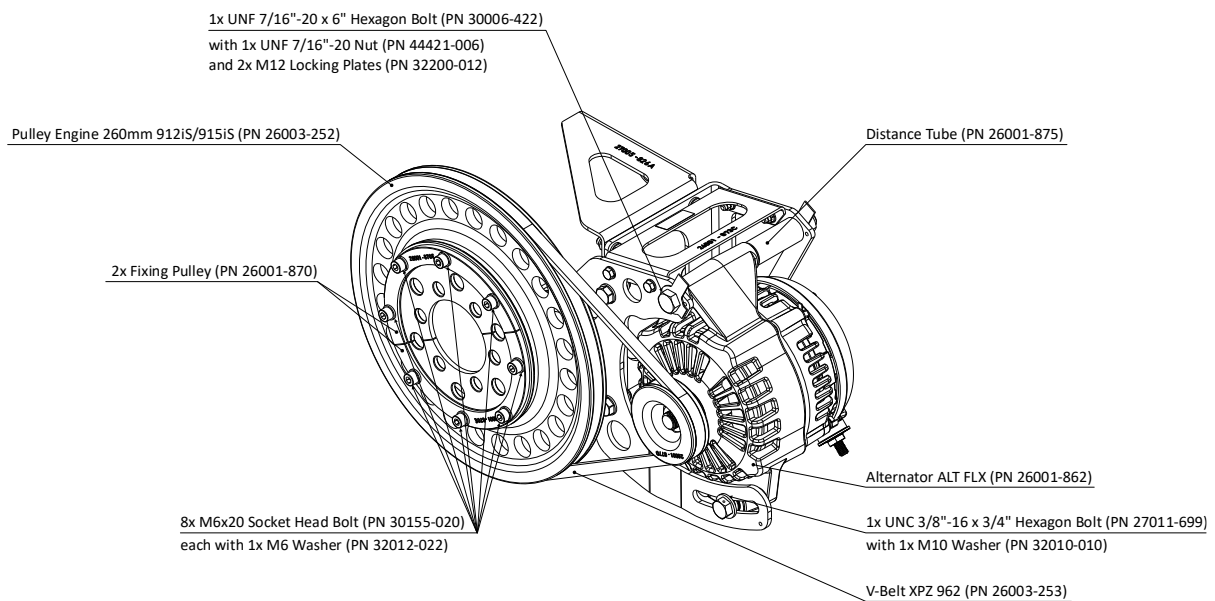

**Figure 5-5: Isometric View Ext. Alternator Kit 150A Rotax 915iS**

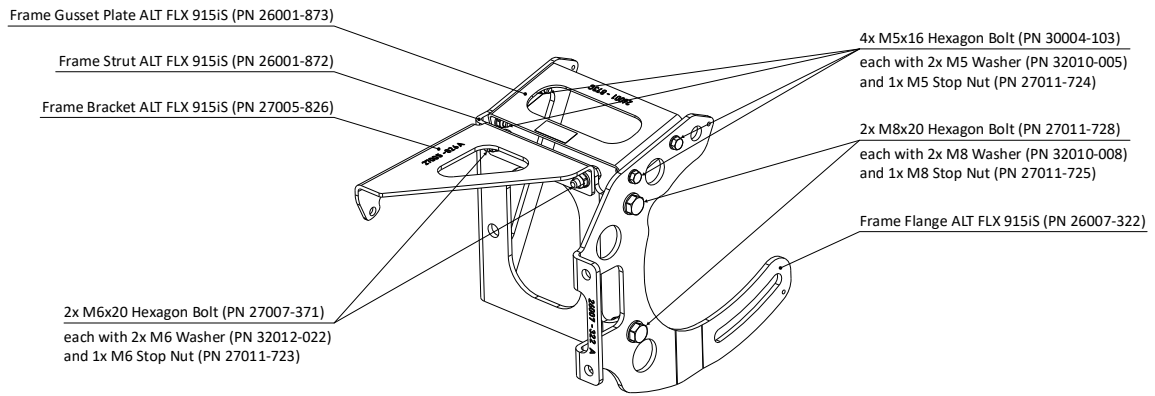

**Figure 5-6: Isometric View Ext. Alternator Kit 150A Rotax 915iS Frames**

## 5.4 Assembly Instructions Ext. Alternator Kit 150A Rotax 916iS

**PN Alternator Kit:** 12-188

**PN Mounting Kit:** 27011-721

1. Mount the **Frame Bracket ALT FLX 915iS** (PN 27005-826) to the Rotax Attachment Points **GR1** and **GL1** with the pre-installed bolts. Do not tighten the bolts yet.
2. Mount the **Frame Flange ALT FLX 915iS** (PN 26007-322) to the Rotax Attachment Points **L5** and **L6** with 2x **M8x20 Hexagon Bolt** (PN 27011-729) and 2x **M8 Washer** (PN 32010-008). Do not tighten the bolts yet.
3. Mount the **Frame Strut ALT FLX 915iS** (PN 26001-872) to the Rotax Attachment Point **L4** with 1x **M10x20 Hexagon Bolt** (PN 27011-731) and 1x **M10 Washer** (PN 32010-010). Do not tighten the bolt yet.
4. Connect the **Frame Flange ALT FLX 915iS** (PN 26007-322) and the **Frame Strut ALT FLX 915iS** (PN 26001-872) with 2x **M8x20 Hexagon Bolt** (PN 27011-728), 4x **M8 Washer** (PN 32010-008) and 2x **M8 Stop Nut** (PN 27011-725). Do not tighten the bolts yet.
5. Connect the **Frame Bracket ALT FLX 915iS** (PN 27005-826) and the **Frame Strut ALT FLX 915iS** (PN 26001-872) with 2x **M6x20 Hexagon Bolt** (PN 27007-371), 4x **M6 Washer** (PN 32012-022) and 2x **M6 Stop Nut** (PN 27011-723). Do not tighten the bolts yet.
6. Mount the **Frame Gusset Plate ALT FLX 915iS** (PN 26001-873) between the **Frame Flange ALT FLX 915iS** (PN 26007-322) and the **Frame Strut ALT FLX 915iS** (PN 26001-872) with 4x **M5x16 Hexagon Bolt** (PN 30004-103), 8x **M5 Washer** (PN 32010-005) and 4x **M5 Stop Nut** (PN 27011-724).
7. Tighten all bolts from steps 1-6 and torque them as specified in **Table 4-1**. Secure the **M10x20 Hexagon Bolt** (PN 27011-731) against the **Frame Strut ALT FLX 915iS** (PN 26001-872) with safety wire. Secure the 2x **M8x20 Hexagon Bolt** (PN 27011-729) against each other with safety wire.
8. Place the **Pulley Engine 260mm 912iS/915iS** (PN 26003-252) behind the propeller flange. Place the 2x **Fixing Pulley 916iS** (PN 27005-829) between the **Pulley Engine 260mm 912iS/915iS** (PN 26003-252) and the propeller flange. The fixing pulleys can be temporarily secured with 2x M10 bolts and 2x M10 nuts (not included) until the propeller is installed.
9. Mount the **Pulley Engine 260mm 912iS/915iS** (PN 26003-252) on the 2x **Fixing Pulley 916iS** (PN 27005-829) with 8x **M6x20 Socket Head Bolt** (PN 30115-020) and 8x **M6 Washer** (PN 32012-022). Apply Loctite 243 on all 8x **M6x20 Socket Head Bolt** (PN 30115-020).
10. Apply battery terminal grease on all connections between the alternator and the bearings.
11. Mount the **Alternator ALT FLX** (PN 26001-862) between the **Frame Flange ALT FLX 915iS** (PN 26007-322) and the **Frame Strut ALT FLX 915iS** (PN 26001-872) by inserting 1x **UNF 7/16"-20 x 6" Hexagon Bolt** (PN 30006-422) with 1x **UNF 7/16"-20 Nut** (PN 44421-006), the **Distance Tube ALT FLX** (PN 26001-875) and 2x **M12 Locking Plates** (PN 32200-012) through the pivot hole of the alternator. Do not tighten the bolt yet.
12. Adjust the position in x-direction between the **Alternator ALT FLX** (PN 26001-862) and the frames using the **Shim Set Alternator** (PN 12-542). Ensure that the **Pulley Engine 260mm 912iS/915iS** (PN 26003-252) and the pre-mounted **Pulley ALT FLX 915iS** (PN 26001-877) are in

- the same plane for proper belt alignment. The assembly needs to fit tight between the **Frame Flange ALT FLX 915iS** (PN 26007-322) and the **Frame Strut ALT FLX 915iS** (PN 26001-872).
13. Mount the **V-Belt XPZ 962** (PN 26003-253) on the **Pulley Engine 260mm 912iS/915iS** (PN 26003-252) and the pre-mounted **Pulley ALT FLX 915iS** (PN 26001-877).
  14. Mount the propeller as described in the propeller manual. The propeller bolts must be inserted through both the Rotax propeller shaft holes and the **Fixing Pulley 916iS** (PN 27005-829) mounting holes.
  15. Move the **Alternator ALT FLX** (PN 26001-862) to tense the belt. Fix the position by inserting 1x **UNC 3/8"-16 x 3/4" Hexagon Bolt** (PN 27011-699) with 1x **M10 Washer** (PN 32010-010) through the slot of the **Frame Flange ALT FLX 915iS** (PN 26007-322) into the adjusting hole of the alternator. The belt will soften during the first few runs and needs to be retightened. Use the **Shim Set Alternator** (PN 12-542) to align the alternator to the frames.
  16. Tighten and torque the **UNC 3/8"-16 x 3/4" Hexagon Bolt** (PN 27011-699) as specified in **Table 4-1**. Secure it against the **Frame Flange ALT FLX 915iS** (PN 26007-322) with safety wire.
  17. Tighten and torque the **UNF 7/16"-20 x 6" Hexagon Bolt** (PN 30006-422) as specified in **Table 4-1**. Bend the edges of the **M12 Locking Plates** (PN 32200-012) according to usual procedure to secure them.
  18. Thoroughly check the complete installation.

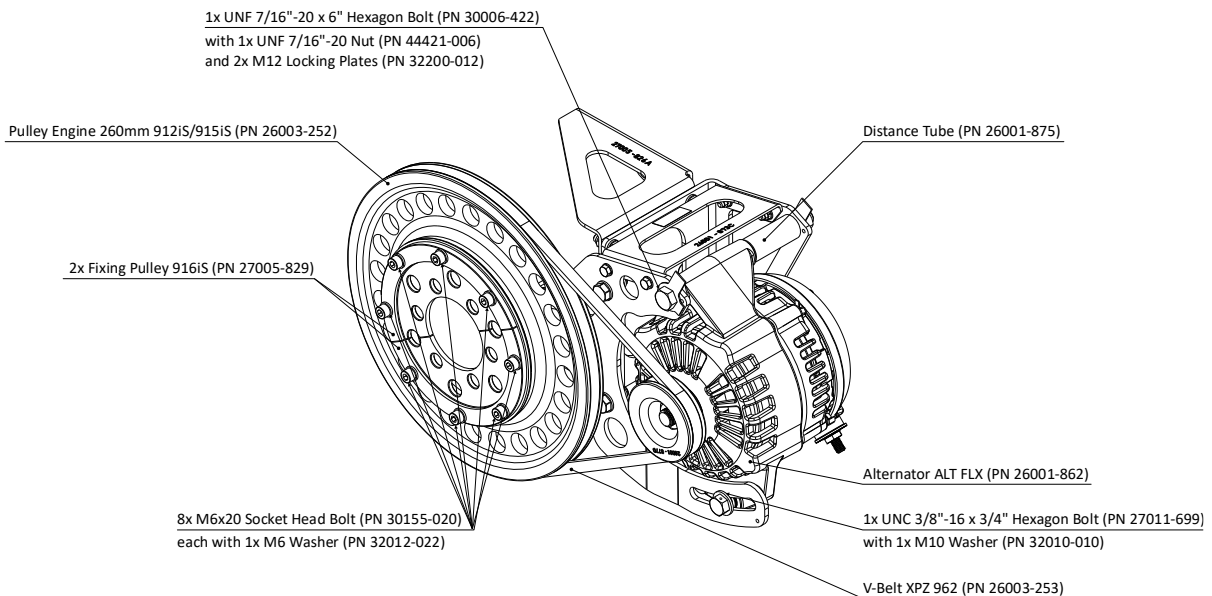

**Figure 5-7: Isometric View Ext. Alternator Kit 150A Rotax 916iS**

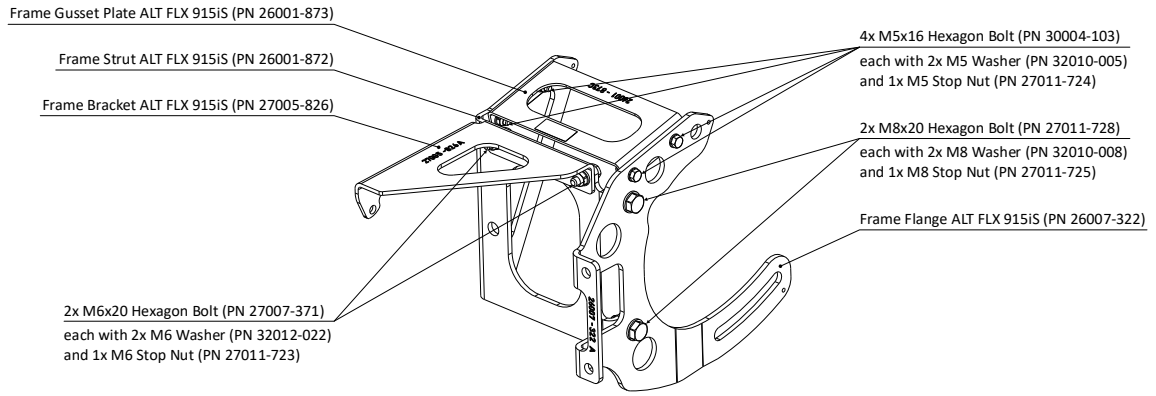

**Figure 5-8: Isometric View Ext. Alternator Kit 150A Rotax 916iS Frames**

## 5.5 Assembly Instructions Ext. Alternator Kit 150A Bank1 Rotax 912iS

**PN Alternator Kit:** 12-230  
**PN Mounting Kit:** 27011-781

1. Mount the **Frame Bracket Bank1 ALT FLX/ES 912iS** (PN 27005-876) to the Rotax Attachment Points **GR1** and **GR2** with the pre-installed bolts. Do not tighten the bolts yet.
2. Mount the **Frame Flange Bank1 ALT FLX 912iS** (PN 27005-884) to the Rotax Attachment Points **R5** and **R6** with the pre-installed bolts and washers. Do not tighten the bolts yet.
3. Mount the **Frame Strut Bank1 ALT FLX 912iS** (PN 27005-885) to the **Frame Flange Bank1 ALT FLX 912iS** (PN 27005-884) with 3x **M6x20 Hexagon Bolt** (PN 27007-371), 6x **M6 Washer** (PN 32012-022) and 3x **M6 Stop Nut** (PN 27011-723). Connect the **Frame Strut Bank1 ALT FLX 912iS** (PN 27005-885) and the **Frame Flange Bank1 ALT FLX 912iS** (PN 27005-884) to the Rotax Attachment Point **R4** with 1x **M10x20 Hexagon Bolt** (PN 27011-731) and 1x **M10 Washer** (PN 32010-010). Do not tighten the bolts yet.
4. Connect the **Frame Bracket Bank1 ALT FLX/ES 912iS** (PN 27005-876) to the **Frame Flange Bank1 ALT FLX 912iS** (PN 27005-884) and **Frame Strut Bank1 ALT FLX 912iS** (PN 27005-885) with 2x **M6x25 Hexagon Bolt** (PN 27011-825), 4x **M6 Washer** (PN 32012-022) and 2x **M6 Stop Nut** (PN 27011-723). Do not tighten the bolts yet.
5. Mount the **Frame Gusset Plate Bank1 ALT FLX 912iS** (PN 27005-886) between the **Frame Flange Bank1 ALT FLX 912iS** (PN 27005-884) and the **Frame Strut Bank1 ALT FLX 912iS** (PN 27005-885) with 4x **M5x16 Hexagon Bolt** (PN 30004-103), 8x **M5 Washer** (PN 32010-005) and 4x **M5 Stop Nut** (PN 27011-724). Do not tighten the bolts yet.
6. Mount the **Frame Crossbar ALT FLX 912iS** (PN 27005-888) to the **Frame Flange Bank1 ALT FLX 912iS** (PN 27005-884) with 2x **M6x20 Hexagon Bolt** (PN 27007-371), 4x **M6 Washer** (PN 32012-022) and 2x **M6 Stop Nut** (PN 27011-723). When operating a Double Alternator Kit, additionally connect the **Frame Crossbar ALT FLX 912iS** (PN 27005-888) to the Bank 2 side according to the instructions of the corresponding Double Alternator Kit.
7. Tighten all bolts from steps 1-6 and torque them as specified in **Table 4-1**. Secure the **M10x20 Hexagon** (PN 27011-731) against the **Frame Flange Bank1 ALT FLX 912iS** (PN 27005-884) with safety wire. Secure the 2x pre-installed bolts on the Rotax Attachment Points **R5** and **R6** against each other with safety wire.
8. Place the **Double-Pulley Engine 260mm 912iS/915iS** (PN 26007-312) behind the propeller flange. Place the 2x **Fixing Pulley** (PN 26001-870) between the **Double-Pulley Engine 260mm 912iS/915iS** (PN 26007-312) and the propeller flange. The fixing pulleys can be temporarily secured with 2x M10 bolts and 2x M10 nuts (not included) until the propeller is installed.
9. Mount the **Double-Pulley Engine 260mm 912iS/915iS** (PN 26007-312) on the 2x **Fixing Pulley** (PN 26001-870) with 8x **M6x20 Socket Head Bolt** (PN 30115-020) and 8x **M6 Washer** (PN 32012-022). Apply Loctite 243 on all 8x **M6x20 Socket Head Bolt** (PN 30115-020).
10. Apply battery terminal grease on all connections between the alternator and the bearings.
11. Mount the **Alternator ALT FLX** (PN 26001-862) between the **Frame Flange Bank1 ALT FLX 912iS** (PN 27005-884) and the **Frame Strut Bank1 ALT FLX 912iS** (PN 27005-885) by inserting 1x **UNF 7/16"-20 x 4" Hexagon Bolt** (PN 27007-507) with 1x **UNF 7/16"-20 Flat Nut** (PN 27007-

- 506) and 2x **M12 Locking Plates** (PN 32200-012) through the pivot hole of the alternator. Do not tighten the bolt yet.
12. Adjust the position in x-direction between the **Alternator ALT FLX** (PN 26001-862) and the frames using the **Shim Set Alternator** (PN 12-542). Ensure that the **Double-Pulley Engine 260mm 912iS/915iS** (PN 26007-312) and the pre-mounted **Pulley ALT FLX 912iS/ULS** (PN 26006-065) are in the same plane for proper belt alignment. The assembly needs to fit tight between the **Frame Flange Bank1 ALT FLX 912iS** (PN 27005-884) and the **Frame Strut Bank1 ALT FLX 912iS** (PN 27005-885).
  13. Mount the **V-Belt XPZ 962** (PN 26003-253) on the **Double-Pulley Engine 260mm 912iS/915iS** (PN 26007-312) and the pre-mounted **Pulley ALT FLX 912iS/ULS** (PN 26006-065).
  14. Mount the propeller as described in the propeller manual. The propeller bolts must be inserted through both the Rotax propeller shaft holes and the **Fixing Pulley** (PN 26001-870) mounting holes.
  15. Move the **Alternator ALT FLX** (PN 26001-862) to tense the belt. Fix the position by inserting 1x **UNC 3/8"-16 x 3/4" Hexagon Bolt** (PN 27011-699) with 1x **M10 Washer** (PN 32010-010) through the slot of the **Frame Flange Bank1 ALT FLX 912iS** (PN 27005-884) into the adjusting hole of the alternator. The belt will soften during the first few runs and needs to be retightened. Use the **Shim Set Alternator** (PN 12-542) to align the alternator to the frames.
  16. Tighten and torque the **UNC 3/8"-16 x 3/4" Hexagon Bolt** (PN 27011-699) as specified in **Table 4-1**. Secure it against the **Frame Flange Bank1 ALT FLX 912iS** (PN 27005-884) with safety wire.
  17. Tighten and torque the **UNF 7/16"-20 x 4" Hexagon Bolt** (PN 27007-507) as specified in **Table 4-1**. Bend the edges of the **M12 Locking Plates** (PN 32200-012) according to usual procedure to secure them.
  18. Thoroughly check the complete installation.

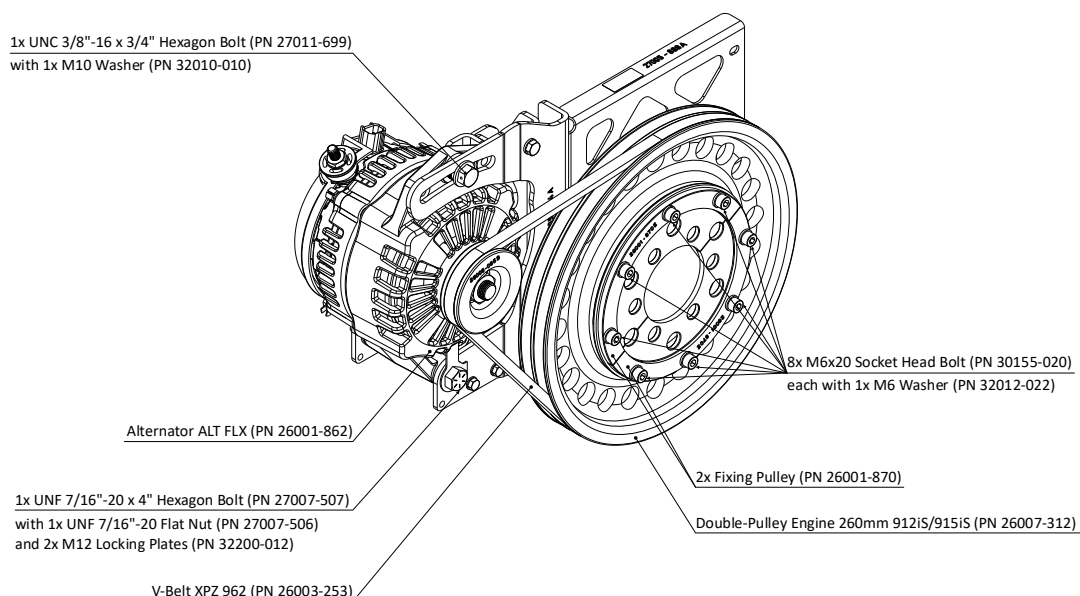

**Figure 5-9: Isometric View Ext. Alternator Kit 150A Bank1 Rotax 912iS**

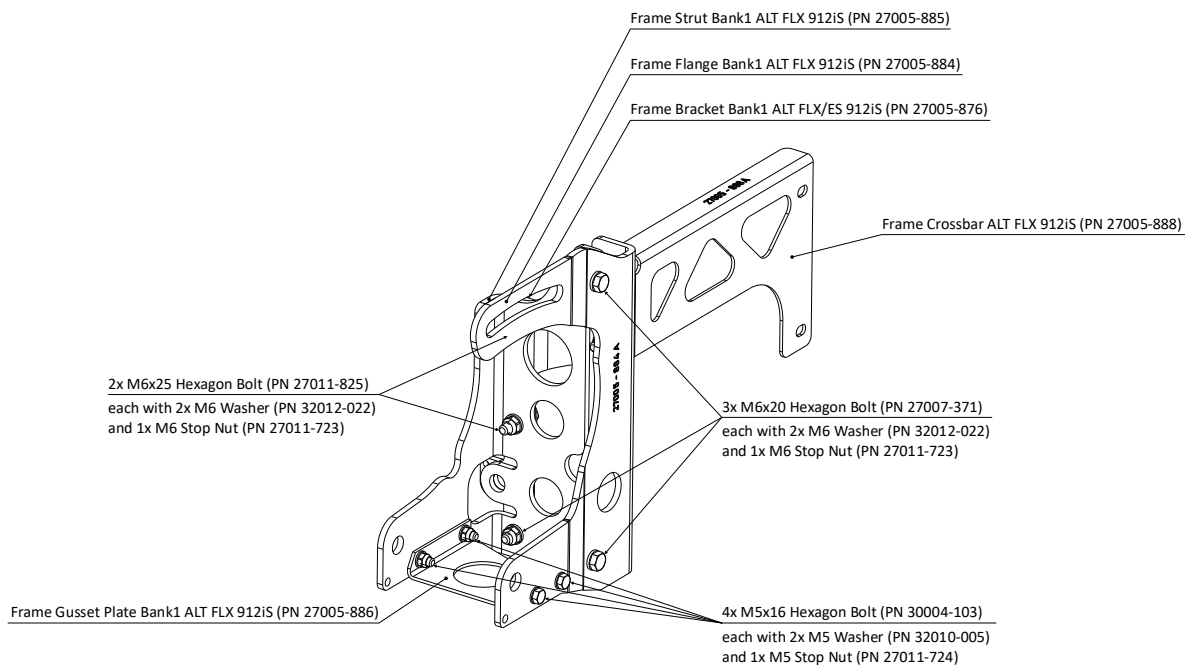

**Figure 5-10: Isometric View Ext. Alternator Kit 150A Bank1 Rotax 912iS Frames**

## 5.6 Assembly Instructions Ext. Alternator Kit 150A Bank1 Rotax 915iS

**PN Alternator Kit:** 12-094

**PN Mounting Kit:** 27011-711

1. Mount the **Frame Flange Bank1 ALT FLX 915iS** (PN 26007-315) to the Rotax Attachment Point **R4** with 1x **M10x20 Hexagon Bolt** (PN 27011-731) and 1x **M10 Washer** (PN 32010-010), and to the Rotax Attachment Points **R5** and **R6** with 2x **M8x20 Hexagon Bolt** (PN 27011-729) and 2x **M8 Washer** (PN 32010-008). Do not tighten the bolts yet.
2. Mount the **Frame Strut Bank1 ALT FLX 915iS** (PN 26007-316) to the **Frame Flange Bank1 ALT FLX 915iS** (PN 26007-315) with 3x **M8x20 Hexagon Bolt** (PN 27011-728), 6x **M8 Washer** (PN 32010-008) and 3x **M8 Stop Nut** (PN 27011-725). Do not tighten the bolts yet.
3. Mount the **Frame Gusset Plate Bank1 ALT FLX 915iS** (PN 26001-317) between the **Frame Flange Bank1 ALT FLX 915iS** (PN 26007-315) and the **Frame Strut Bank1 ALT FLX 915iS** (PN 26007-316) with 4x **M5x16 Hexagon Bolt** (PN 30004-103), 8x **M5 Washer** (PN 32010-005) and 4x **M5 Stop Nut** (PN 27011-724). Do not tighten the bolts yet.
4. Mount the **Frame Crossbar ALT FLX 915iS** (PN 26007-319) to the **Frame Flange Bank1 ALT FLX 915iS** (PN 26007-315) with 2x **M6x20 Hexagon Bolt** (PN 27007-371), 4x **M6 Washer** (PN 32012-022) and 2x **M6 Stop Nut** (PN 27011-723), and to the Rotax Attachment Points **GR1** and **GL1** with the pre-installed bolts. When operating a Double Alternator Kit, additionally connect the **Frame Crossbar ALT FLX 915iS** (PN 26007-319) to the Bank 2 side according to the instructions of the corresponding Double Alternator Kit.
5. Tighten all bolts from steps 1-4 and torque them as specified in **Table 4-1**. Secure the **M10x20 Hexagon Bolt** (PN 27011-731) against the **Frame Flange Bank1 ALT FLX 915iS** (PN 26007-315) with safety wire. Secure the 2x **M8x20 Hexagon Bolt** (PN 27011-729) against each other with safety wire.
6. Place the **Double-Pulley Engine 260mm 912iS/915iS** (PN 26007-312) behind the propeller flange. Place the 2x **Fixing Pulley** (PN 26001-870) between the **Double-Pulley Engine 260mm 912iS/915iS** (PN 26007-312) and the propeller flange. The fixing pulleys can be temporarily secured with 2x M10 bolts and 2x M10 nuts (not included) until the propeller is installed.
7. Mount the **Double-Pulley Engine 260mm 912iS/915iS** (PN 26007-312) on the 2x **Fixing Pulley** (PN 26001-870) with 8x **M6x20 Socket Head Bolt** (PN 30115-020) and 8x **M6 Washer** (PN 32012-022). Apply Loctite 243 on all 8x **M6x20 Socket Head Bolt** (PN 30115-020).
8. Apply battery terminal grease on all connections between the alternator and the bearings.
9. Place the **Alternator ALT FLX** (PN 26001-862) between the **Frame Flange Bank1 ALT FLX 915iS** (PN 26007-315) and the **Frame Strut Bank1 ALT FLX 915iS** (PN 26007-316) by inserting 1x **UNF 7/16"-20 x 4" Hexagon Bolt** (PN 27007-507) with 1x **UNF 7/16"-20 Flat Nut** (PN 27007-506) and 2x **M12 Locking Plates** (PN 32200-012) through the pivot hole of the alternator. Do not tighten the bolt yet.
10. Adjust the position in x-direction between the **Alternator ALT FLX** (PN 26001-862) and the frames using the **Shim Set Alternator** (PN 12-542). Ensure that the **Double-Pulley Engine 260mm 912iS/915iS** (PN 26007-312) and the pre-mounted **Pulley ALT FLX 915iS** (PN 26001-877) are in the same plane for proper belt alignment. The assembly needs to fit tight between

the **Frame Flange Bank1 ALT FLX 915iS** (PN 26007-315) and the **Frame Strut Bank1 ALT FLX 915iS** (PN 26007-316).

11. Mount the **V-Belt XPZ 962** (PN 26003-253) on the **Double-Pulley Engine 260mm 912iS/915iS** (PN 26007-312) and the pre-mounted **Pulley ALT FLX 915iS** (PN 26001-877).
12. Mount the propeller as described in the propeller manual. The propeller bolts must be inserted through both the Rotax propeller shaft holes and the **Fixing Pulley** (PN 26001-870) mounting holes.
13. Move the **Alternator ALT FLX** (PN 26001-862) to tense the belt. Fix the position by inserting 1x **UNC 3/8"-16 x 3/4" Hexagon Bolt** (PN 27011-699) with 1x **M10 Washer** (PN 32010-010) through the slot of the **Frame Flange Bank1 ALT FLX 915iS** (PN 26007-315) into the adjusting hole of the alternator. The belt will soften during the first few runs and needs to be retightened. Use the **Shim Set Alternator** (PN 12-542) to align the alternator to the frames.
14. Tighten and torque the **UNC 3/8"-16 x 3/4" Hexagon Bolt** (PN 27011-699) as specified in **Table 4-1**. Secure it against the **Frame Flange Bank1 ALT FLX 915iS** (PN 26007-315) with safety wire.
15. Tighten and torque the **UNF 7/16"-20 x 4" Hexagon Bolt** (PN 27007-507) as specified in **Table 4-1**. Bend the edges of the **M12 Locking Plates** (PN 32200-012) according to usual procedure to secure them.
16. Thoroughly check the complete installation.

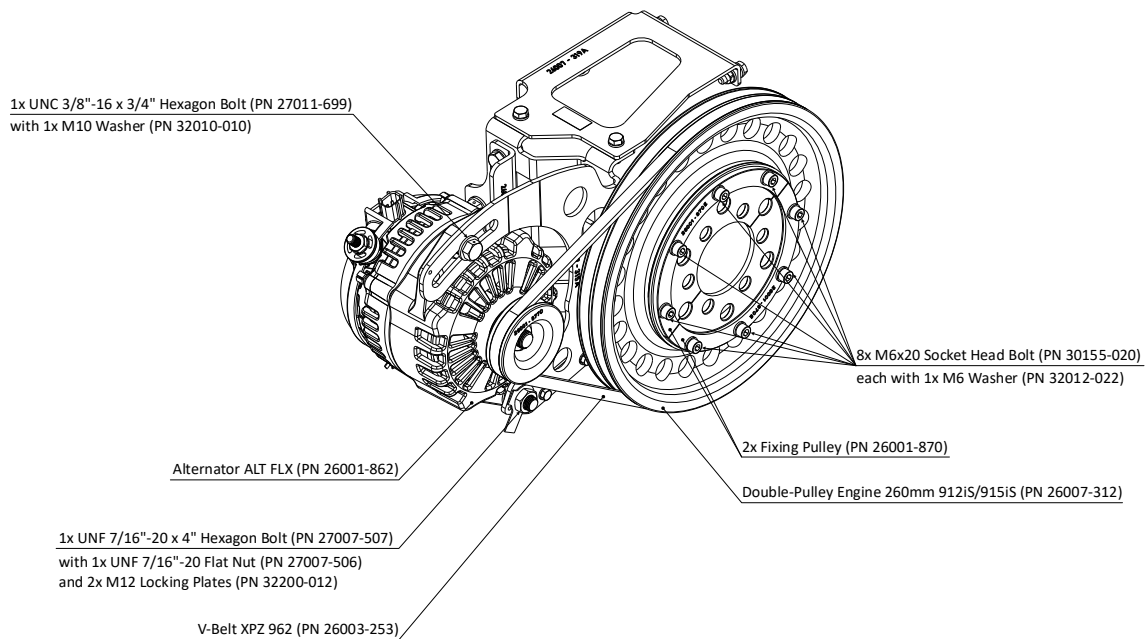

**Figure 5-11: Isometric View Ext. Alternator Kit 150A Bank1 Rotax 915iS**

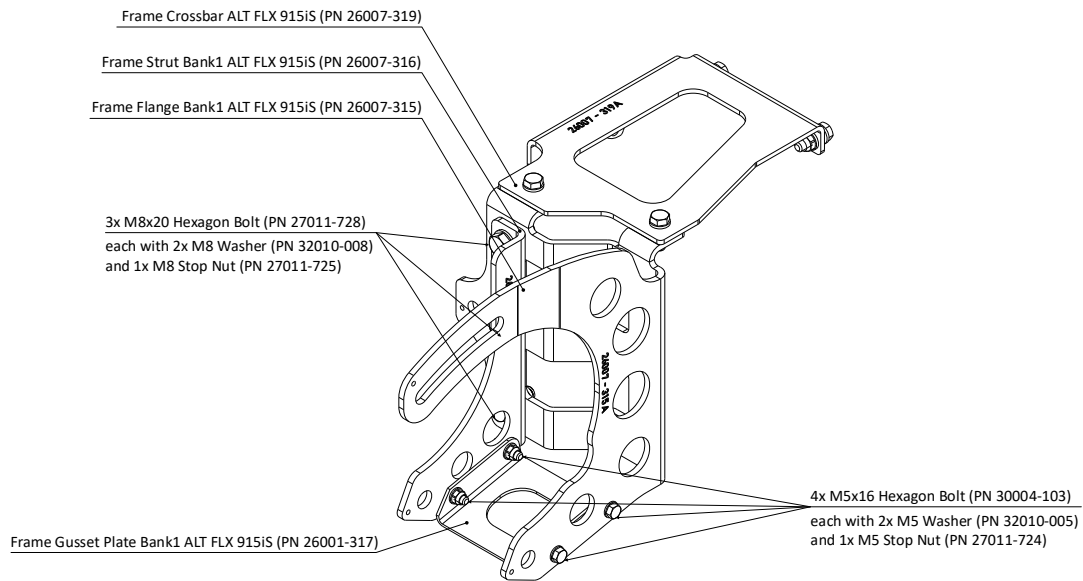

**Figure 5-12: Isometric View Ext. Alternator Kit 150A Bank1 Rotax 915iS Frames**

## 5.7 Assembly Instructions Ext. Alternator Kit 150A Bank1 Rotax 916iS

**PN Alternator Kit:** 12-571

**PN Mounting Kit:** 27011-701

1. Mount the **Frame Flange Bank1 ALT FLX 915iS** (PN 26007-315) to the Rotax Attachment Point **R4** with 1x **M10x20 Hexagon Bolt** (PN 27011-731) and 1x **M10 Washer** (PN 32010-010), and to the Rotax Attachment Points **R5** and **R6** with 2x **M8x20 Hexagon Bolt** (PN 27011-729) and 2x **M8 Washer** (PN 32010-008). Do not tighten the bolts yet.
2. Mount the **Frame Strut Bank1 ALT FLX 915iS** (PN 26007-316) to the **Frame Flange Bank1 ALT FLX 915iS** (PN 26007-315) with 3x **M8x20 Hexagon Bolt** (PN 27011-728), 6x **M8 Washer** (PN 32010-008) and 3x **M8 Stop Nut** (PN 27011-725). Do not tighten the bolts yet.
3. Mount the **Frame Gusset Plate Bank1 ALT FLX 915iS** (PN 26001-317) between the **Frame Flange Bank1 ALT FLX 915iS** (PN 26007-315) and the **Frame Strut Bank1 ALT FLX 915iS** (PN 26007-316) with 4x **M5x16 Hexagon Bolt** (PN 30004-103), 8x **M5 Washer** (PN 32010-005) and 4x **M5 Stop Nut** (PN 27011-724). Do not tighten the bolts yet.
4. Mount the **Frame Crossbar ALT FLX 915iS** (PN 26007-319) to the **Frame Flange Bank1** with 2x **M6x20 Hexagon Bolt** (PN 27007-371), 4x **M6 Washer** (PN 32012-022) and 2x **M6 Stop Nut** (PN 27011-723), and to the Rotax Attachment Points **GR1** and **GL1** with the pre-installed bolts. When operating a Double Alternator Kit, additionally connect the **Frame Crossbar ALT FLX 915iS** (PN 26007-319) to the Bank 2 side according to the instructions of the corresponding Double Alternator Kit.
5. Tighten all bolts from steps 5.61-4 and torque them as specified in **Table 4-1**. Secure the **M10x20 Hexagon Bolt** (PN 27011-731) against the **Frame Flange Bank1 ALT FLX 915iS** (PN 26007-315) with safety wire. Secure the 2x **M8x20 Hexagon Bolt** (PN 27011-729) against each other with safety wire.
6. Place the **Double-Pulley Engine 260mm 912iS/915iS** (PN 26007-312) behind the propeller flange. Place the 2x **Fixing Pulley 916iS** (PN 27005-829) between the **Double-Pulley Engine 260mm 912iS/915iS** (PN 26007-312) and the propeller flange. The fixing pulleys can be temporarily secured with 2x M10 bolts and 2x M10 nuts (not included) until the propeller is installed.
7. Mount the **Double-Pulley Engine 260mm 912iS/915iS** (PN 26007-312) on the 2x **Fixing Pulley 916iS** (PN 27005-829) with 8x **M6x20 Socket Head Bolt** (PN 30115-020) and 8x **M6 Washer** (PN 32012-022). Apply Loctite 243 on all 8x **M6x20 Socket Head Bolt** (PN 30115-020).
8. Apply battery terminal grease on all connections between the alternator and the bearings.
9. Place the **Alternator ALT FLX** (PN 26001-862) between the **Frame Flange Bank1 ALT FLX 915iS** (PN 26007-315) and the **Frame Strut Bank1 ALT FLX 915iS** (PN 26007-316) by inserting 1x **UNF 7/16"-20 x 4" Hexagon Bolt** (PN 27007-507) with 1x **UNF 7/16"-20 Flat Nut** (PN 27007-506) and 2x **M12 Locking Plates** (PN 32200-012) through the pivot hole of the alternator. Do not tighten the bolt yet.
10. Adjust the position in x-direction between the **Alternator ALT FLX** (PN 26001-862) and the frames using the **Shim Set Alternator** (PN 12-542). Ensure that the **Double-Pulley Engine 260mm 912iS/915iS** (PN 26007-312) and the pre-mounted **Pulley ALT FLX 915iS** (PN 26001-877) are in the same plane for proper belt alignment. The assembly needs to fit tight between

the **Frame Flange Bank1 ALT FLX 915iS** (PN 26007-315) and the **Frame Strut Bank1 ALT FLX 915iS** (PN 26007-316).

11. Mount the **V-Belt XPZ 962** (PN 26003-253) on the **Double-Pulley Engine 260mm 912iS/915iS** (PN 26007-312) and the pre-mounted **Pulley ALT FLX 915iS** (PN 26001-877).
12. Mount the propeller as described in the propeller manual. The propeller bolts must be inserted through both the Rotax propeller shaft holes and the **Fixing Pulley** (PN 26001-870) mounting holes.
13. Move the **Alternator ALT FLX** (PN 26001-862) to tense the belt. Fix the position by inserting 1x **UNC 3/8"-16 x 3/4" Hexagon Bolt** (PN 27011-699) with 1x **M10 Washer** (PN 32010-010) through the slot of the **Frame Flange Bank1 ALT FLX 915iS** (PN 26007-315) into the adjusting hole of the alternator. The belt will soften during the first few runs and needs to be retightened. Use the **Shim Set Alternator** (PN 12-542) to align the alternator to the frames.
14. Tighten and torque the **UNC 3/8"-16 x 3/4" Hexagon Bolt** (PN 27011-699) as specified in **Table 4-1**. Secure it against the **Frame Flange Bank1 ALT FLX 915iS** (PN 26007-315) with safety wire.
15. Tighten and torque the **UNF 7/16"-20 x 4" Hexagon Bolt** (PN 27007-507) as specified in **Table 4-1**. Bend the edges of the **M12 Locking Plates** (PN 32200-012) according to usual procedure to secure them.
16. Thoroughly check the complete installation.

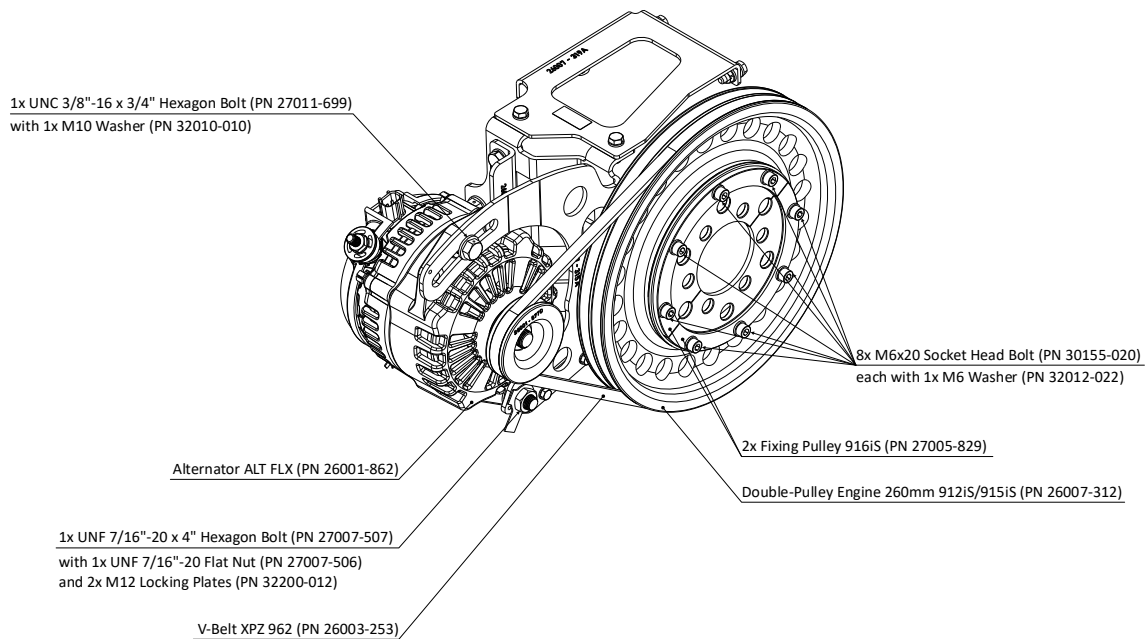

**Table 5-1: Isometric View Ext. Alternator Kit 150A Bank1 Rotax 916iS**

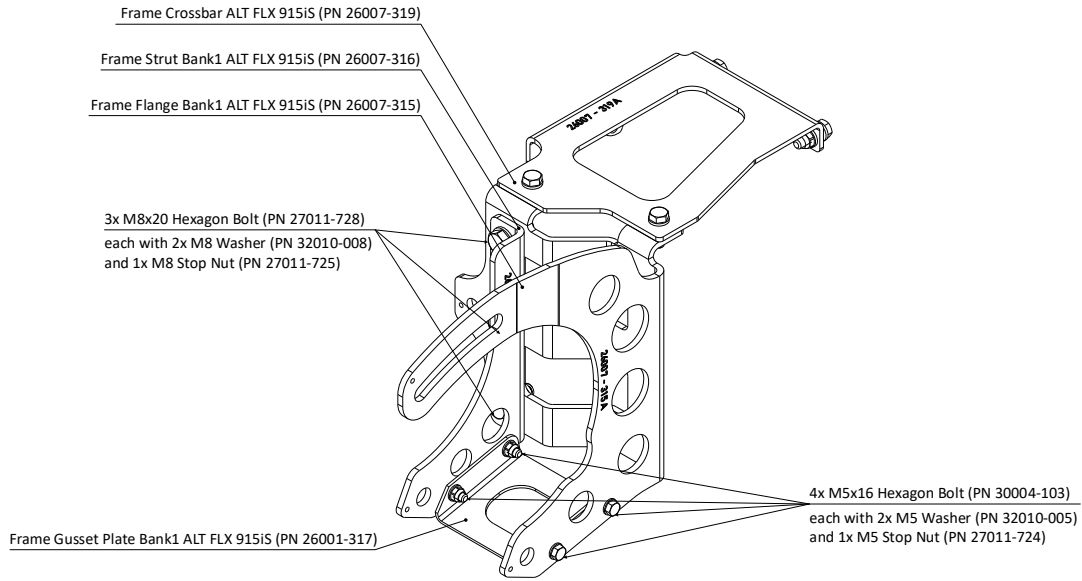

**Figure 5-13: Isometric View Ext. Alternator Kit 150A Bank1 Rotax 916iS Frames**

## 5.8 Assembly Instructions Ext. Double Alternator Kit 2x 150A Rotax 912iS

**PN Alternator Kit:** 11-239  
**PN Mounting Kit:** 27005-881

1. Mount the **Frame Bracket ALT FLX/ES 912iS** (PN 26006-068) to the Rotax Attachment Points **GL1** and **GL2** with the pre-installed bolts. Do not tighten the bolts yet.
2. Mount the **Frame Flange ALT FLX 912iS** (PN 26006-064) to the Rotax Attachment Points **L5** and **L6** with 2x **M8x20 Hexagon Bolt** (PN 27011-729) and 2x **M8 Washer** (PN 32010-008). Do not tighten the bolts yet.
3. Mount the **Frame Strut ALT FLX 912iS** (PN 26006-063) to the Rotax Attachment Point **L4** with 1x **M10x20 Hexagon Bolt** (PN 27011-731) and 1x **M10 Washer** (PN 32010-010). Do not tighten the bolt yet.
4. Connect the **Frame Flange ALT FLX 912iS** (PN 26006-064) and the **Frame Strut ALT FLX 912iS** (PN 26006-063) with 3x **M6x20 Hexagon Bolt** (PN 27007-371), 6x **M6 Washer** (PN 32012-022) and 3x **M6 Stop Nut** (PN 27011-723). Do not tighten the bolts yet.
5. Connect the **Frame Bracket ALT FLX/ES 912iS** (PN 26006-068) and the **Frame Strut ALT FLX 912iS** (PN 26006-063) with 2x **M6x20 Hexagon Bolt** (PN 27007-371), 4x **M6 Washer** (PN 32012-022) and 2x **M6 Stop Nut** (PN 27011-723). Do not tighten the bolts yet.
6. Mount the **Frame Gusset Plate ALT FLX 912iS/ULS** (PN 26006-078) between the **Frame Flange ALT FLX 912iS** (PN 26006-064) and the **Frame Strut ALT FLX 912iS** (PN 26006-063) with 4x **M5x16 Hexagon Bolt** (PN 30004-103), 8x **M5 Washer** (PN 32010-005) and 4x **M5 Stop Nut** (PN 27011-724).
7. Tighten all bolts from steps 5.21-5.26 and torque them as specified in **Table 4-1**. Secure the **M10x20 Hexagon Bolt** (PN 27011-731) against the **Frame Strut ALT FLX 912iS** (PN 26006-063) with safety wire. Secure the 2x **M8x20 Hexagon Bolt** (PN 27011-729) against each other with safety wire.
8. Mount the **Frame Bracket Bank1 ALT FLX/ES 912iS** (PN 27005-876) to the Rotax Attachment Points **GR1** and **GR2** with the pre-installed bolts. Do not tighten the bolts yet.
9. Mount the **Frame Flange Bank1 ALT FLX 912iS** (PN 27005-884) to the Rotax Attachment Points **R5** and **R6** with the pre-installed bolts and washers. Do not tighten the bolts yet.
10. Mount the **Frame Strut Bank1 ALT FLX 912iS** (PN 27005-885) to the **Frame Flange Bank1 ALT FLX 912iS** (PN 27005-884) with 3x **M6x20 Hexagon Bolt** (PN 27007-371), 6x **M6 Washer** (PN 32012-022) and 3x **M6 Stop Nut** (PN 27011-723). Connect the **Frame Strut Bank1 ALT FLX 912iS** (PN 27005-885) and the **Frame Flange Bank1 ALT FLX 912iS** (PN 27005-884) to the Rotax Attachment Point **R4** with 1x **M10x20 Hexagon Bolt** (PN 27011-731) and 1x **M10 Washer** (PN 32010-010). Do not tighten the bolts yet.
11. Connect the **Frame Bracket Bank1 ALT FLX/ES 912iS** (PN 27005-876) to the **Frame Flange Bank1 ALT FLX 912iS** (PN 27005-884) and **Frame Strut Bank1 ALT FLX 912iS** (PN 27005-885) with 2x **M6x25 Hexagon Bolt** (PN 27011-825), 4x **M6 Washer** (PN 32012-022) and 2x **M6 Stop Nut** (PN 27011-723). Do not tighten the bolts yet.
12. Mount the **Frame Gusset Plate Bank1 ALT FLX 912iS** (PN 27005-886) between the **Frame Flange Bank1 ALT FLX 912iS** (PN 27005-884) and the **Frame Strut Bank1 ALT FLX 912iS**

- (PN 27005-885) with 4x **M5x16 Hexagon Bolt** (PN 30004-103), 8x **M5 Washer** (PN 32010-005) and 4x **M5 Stop Nut** (PN 27011-724). Do not tighten the bolts yet.
13. Mount the **Frame Crossbar ALT FLX 912iS** (PN 27005-888) to the **Frame Flange Bank1 ALT FLX 912iS** (PN 27005-884) with 2x **M6x20 Hexagon Bolt** (PN 27007-371), 4x **M6 Washer** (PN 32012-022) and 2x **M6 Stop Nut** (PN 27011-723), and to the **Frame Flange ALT FLX 912iS** (PN 26006-064) and the **Frame Strut ALT FLX 912iS** (PN 26006-063) with 2x **Hexagon Bolt M6x25** (PN 27011-825), 4x **M6 Washer** (PN 32012-022) and 2x **M6 Stop Nut** (PN 27011-723).
  14. Tighten all bolts from steps 8-13 and torque them as specified in **Table 4-1**. Secure the **M10x20 Hexagon** (PN 27011-731) against the **Frame Flange Bank1 ALT FLX 912iS** (PN 27005-884) with safety wire. Secure the 2x pre-installed bolts on the Rotax Attachment Points **R5** and **R6** against each other with safety wire.
  15. Place the **Double-Pulley Engine 260mm 912iS/915iS** (PN 26007-312) behind the propeller flange. Place the 2x **Fixing Pulley** (PN 26001-870) between the **Double-Pulley Engine 260mm 912iS/915iS** (PN 26007-312) and the propeller flange. The fixing pulleys can be temporarily secured with 2x M10 bolts and 2x M10 nuts (not included) until the propeller is installed.
  16. Mount the **Double-Pulley Engine 260mm 912iS/915iS** (PN 26007-312) on the 2x **Fixing Pulley** (PN 26001-870) with 8x **M6x20 Socket Head Bolt** (PN 30115-020) and 8x **M6 Washer** (PN 32012-022). Apply Loctite 243 on all 8x **M6x20 Socket Head Bolt** (PN 30115-020).
  17. Apply battery terminal grease on all connections between the alternator and the bearings.
  18. Mount one **Alternator ALT FLX** (PN 26001-862) between the **Frame Flange ALT FLX 912iS** (PN 26006-064) and the **Frame Strut ALT FLX 912iS** (PN 26006-063) by inserting 1x **UNF 7/16"-20 x 4" Hexagon Bolt** (PN 27007-507) with 1x **UNF 7/16"-20 Flat Nut** (PN 27007-506) and 2x **M12 Locking Plates** (PN 32200-012) through the pivot hole of the alternator. Do not tighten the bolt yet.
  19. Adjust the position in x-direction between the **Alternator ALT FLX** (PN 26001-862) and the frames using the **Shim Set Alternator** (PN 12-542). Ensure that the **Pulley Engine 260mm 912iS/915iS** (PN 26003-252) and the pre-mounted **Pulley ALT FLX 912iS/ULS** (PN 26006-065) are in the same plane for proper belt alignment. The assembly needs to fit tight between the **Frame Flange ALT FLX 912iS** (PN 26006-064) and the **Frame Strut ALT FLX 912iS** (PN 26006-063).
  20. Mount the other **Alternator ALT FLX** (PN 26001-862) between the **Frame Flange Bank1 ALT FLX 912iS** (PN 27005-884) and the **Frame Strut Bank1 ALT FLX 912iS** (PN 27005-885) by inserting 1x **UNF 7/16"-20 x 4" Hexagon Bolt** (PN 27007-507) with 1x **UNF 7/16"-20 Flat Nut** (PN 27007-506) and 2x **M12 Locking Plates** (PN 32200-012) through the pivot hole of the alternator. Do not tighten the bolt yet.
  21. Adjust the position in x-direction between the **Alternator ALT FLX** (PN 26001-862) and the frames using the **Shim Set Alternator** (PN 12-542). Ensure that the **Double-Pulley Engine 260mm 912iS/915iS** (PN 26007-312) and the pre-mounted **Pulley ALT FLX 912iS/ULS** (PN 26006-065) are in the same plane for proper belt alignment. The assembly needs to fit tight between the **Frame Flange Bank1 ALT FLX 912iS** (PN 27005-884) and the **Frame Strut Bank1 ALT FLX 912iS** (PN 27005-885).
  22. Mount one **V-Belt XPZ 962** (PN 26003-253) on the **Double-Pulley Engine 260mm 912iS/915iS** (PN 26007-312) and the pre-mounted **Pulley ALT FLX 912iS/ULS** (PN 26006-065) on Bank 2

- side, and the other **V-Belt XPZ 962** (PN 26003-253) on the **Double-Pulley Engine 260mm 912iS/915iS** (PN 26007-312) and the pre-mounted **Pulley ALT FLX 912iS/ULS** (PN 26006-065) on Bank 1 side.
23. Mount the propeller as described in the propeller manual. The propeller bolts must be inserted through both the Rotax propeller shaft holes and the **Fixing Pulley** (PN 26001-870) mounting holes.
  24. Move the **Alternator ALT FLX** (PN 26001-862) on Bank 2 side to tense the corresponding belt. Fix the position by inserting 1x **UNC 3/8"-16 x 3/4" Hexagon Bolt** (PN 27011-699) with 1x **M10 Washer** (PN 32010-010) through the slot of the **Frame Flange ALT FLX 912iS** (PN 26006-064) into the adjusting hole of the alternator. The belt will soften during the first few runs and needs to be retightened. Use the **Shim Set Alternator** (PN 12-542) to align the alternator to the frames.
  25. Tighten and torque the **UNC 3/8"-16 x 3/4" Hexagon Bolt** (PN 27011-699) as specified in **Table 4-1**. Secure it against the **Frame Flange ALT FLX 912iS** (PN 26006-064) with safety wire.
  26. Tighten and torque the **UNF 7/16"-20 x 4" Hexagon Bolt** (PN 27007-507) as specified in **Table 4-1**. Bend the edges of the **M12 Locking Plates** (PN 32200-012) according to usual procedure to secure them.
  27. Move the **Alternator ALT FLX** (PN 26001-862) on Bank 1 side to tense the corresponding belt. Fix the position by inserting 1x **UNC 3/8"-16 x 3/4" Hexagon Bolt** (PN 27011-699) with 1x **M10 Washer** (PN 32010-010) through the slot of the **Frame Flange Bank1 ALT FLX 912iS** (PN 27005-884) into the adjusting hole of the alternator. The belt will soften during the first few runs and needs to be retightened. Use the **Shim Set Alternator** (PN 12-542) to align the alternator to the frames.
  28. Tighten and torque the **UNC 3/8"-16 x 3/4" Hexagon Bolt** (PN 27011-699) as specified in **Table 4-1**. Secure it against the **Frame Flange Bank1 ALT FLX 912iS** (PN 27005-884) with safety wire.
  29. Tighten and torque the **UNF 7/16"-20 x 4" Hexagon Bolt** (PN 27007-507) as specified in **Table 4-1**. Bend the edges of the **M12 Locking Plates** (PN 32200-012) according to usual procedure to secure them.
  30. Thoroughly check the complete installation.

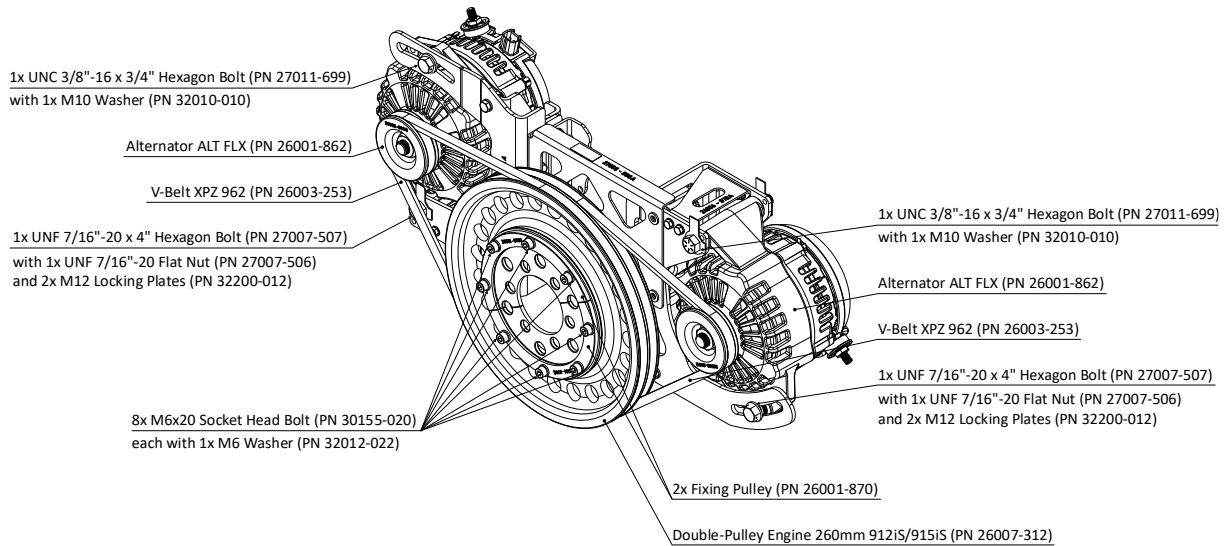

**Figure 5-14: Isometric View Ext. Double Alternator Kit 2x 150A Rotax 912iS**

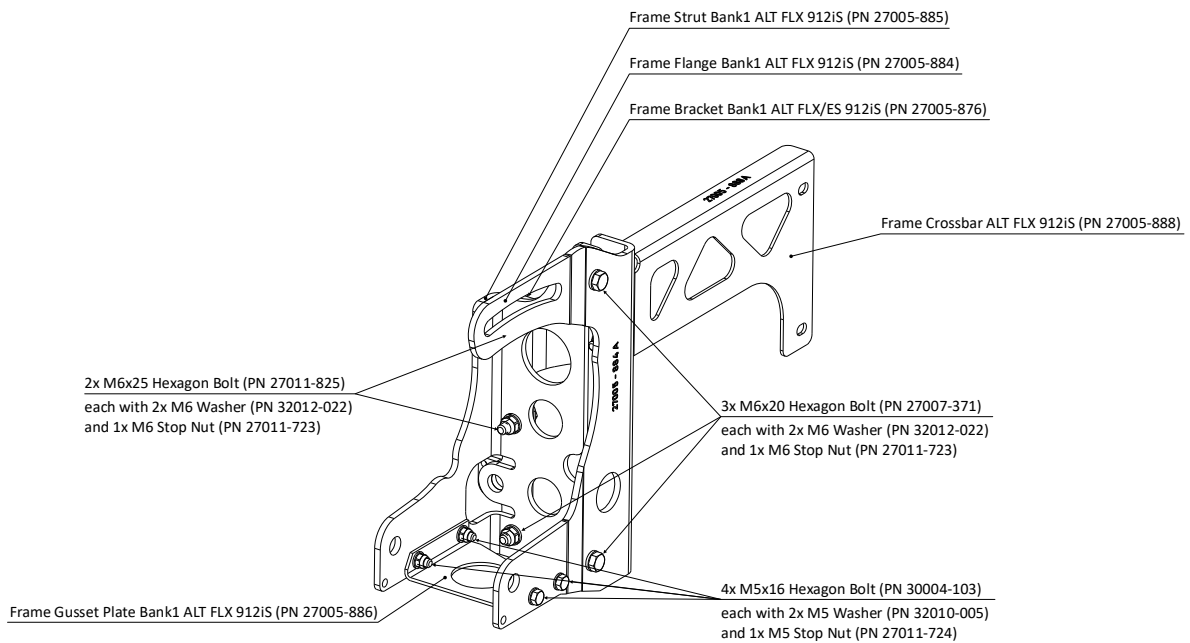

**Figure 5-15: Isometric View Ext. Double Alternator Kit 2x 150A Rotax 912iS Frames Bank1**

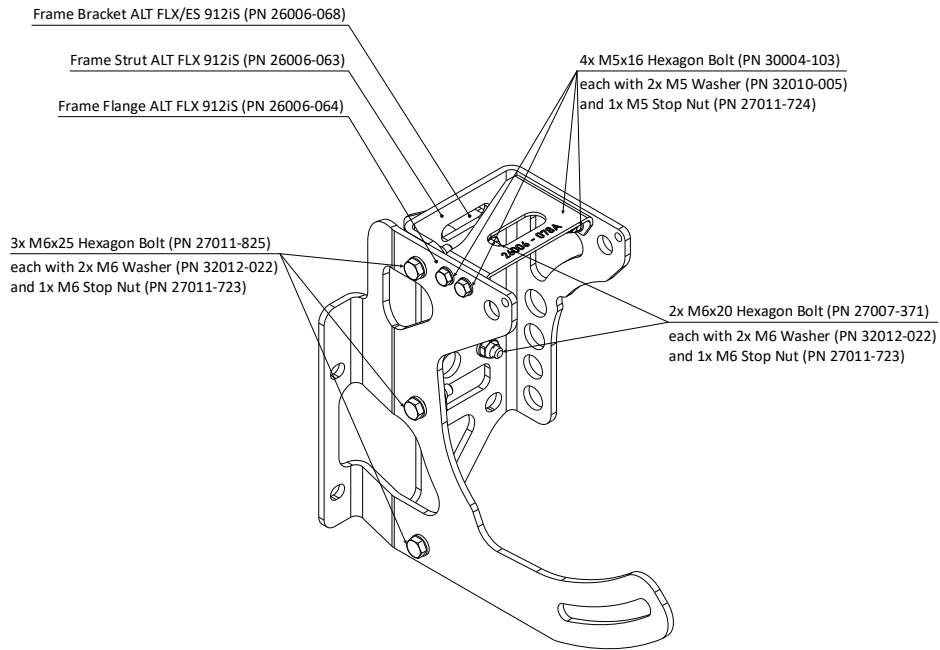

**Figure 5-16: Isometric View Ext. Double Alternator Kit 2x 150A Rotax 912iS Frames Bank2**

## 5.9 Assembly Instructions Ext. Double Alternator Kit 2x 150A Rotax 915iS

**PN Alternator Kit:** 10-916  
**PN Mounting Kit:** 26007-311

1. Mount the **Frame Flange ALT FLX 915iS** (PN 26007-322) to the Rotax Attachment Points **L5** and **L6** with 2x **M8x20 Hexagon Bolt** (PN 27011-729) and 2x **M8 Washer** (PN 32010-008). Do not tighten the bolts yet.
2. Mount the **Frame Strut ALT FLX 915iS** (PN 26001-872) to the Rotax Attachment Point **L4** with 1x **M10x20 Hexagon Bolt** (PN 27011-731) and 1x **M10 Washer** (PN 32010-010). Do not tighten the bolt yet.
3. Connect the **Frame Flange ALT FLX 915iS** (PN 26007-322) and the **Frame Strut ALT FLX 915iS** (PN 26001-872) with 2x **M8x20 Hexagon Bolt** (PN 27011-728), 4x **M8 Washer** (PN 32010-008) and 2x **M8 Stop Nut** (PN 27011-725). Do not tighten the bolts yet.
4. Mount the **Frame Gusset Plate ALT FLX 915iS** (PN 26001-873) between the **Frame Flange ALT FLX 915iS** (PN 26007-322) and the **Frame Strut ALT FLX 915iS** (PN 26001-872) with 4x **M5x16 Hexagon Bolt** (PN 30004-103), 8x **M5 Washer** (PN 32010-005) and 4x **M5 Stop Nut** (PN 27011-724).
5. Tighten all bolts from steps 1-4 and torque them as specified in **Table 4-1**. Secure the **M10x20 Hexagon Bolt** (PN 27011-731) against the **Frame Strut ALT FLX 915iS** (PN 26001-872) with safety wire. Secure the 2x **M8x20 Hexagon Bolt** (PN 27011-729) against each other with safety wire.
6. Mount the **Frame Flange Bank1 ALT FLX 915iS** (PN 26007-315) to the Rotax Attachment Point **R4** with 1x **M10x20 Hexagon Bolt** (PN 27011-731) and 1x **M10 Washer** (PN 32010-010), and to the Rotax Attachment Points **R5** and **R6** with 2x **M8x20 Hexagon Bolt** (PN 27011-729) and 2x **M8 Washer** (PN 32010-008). Do not tighten the bolts yet.
7. Mount the **Frame Strut Bank1 ALT FLX 915iS** (PN 26007-316) to the **Frame Flange Bank1 ALT FLX 915iS** (PN 26007-315) with 3x **M8x20 Hexagon Bolt** (PN 27011-728), 6x **M8 Washer** (PN 32010-008) and 3x **M8 Stop Nut** (PN 27011-725). Do not tighten the bolts yet.
8. Mount the **Frame Gusset Plate Bank1 ALT FLX 915iS** (PN 26001-317) between the **Frame Flange Bank1 ALT FLX 915iS** (PN 26007-315) and the **Frame Strut Bank1 ALT FLX 915iS** (PN 26007-316) with 4x **M5x16 Hexagon Bolt** (PN 30004-103), 8x **M5 Washer** (PN 32010-005) and 4x **M5 Stop Nut** (PN 27011-724). Do not tighten the bolts yet.
9. Mount the **Frame Crossbar ALT FLX 915iS** (PN 26007-319) to the **Frame Flange Bank1 ALT FLX 915iS** (PN 26007-315) with 2x **M6x20 Hexagon Bolt** (PN 27007-371), 4x **M6 Washer** (PN 32012-022) and 2x **M6 Stop Nut** (PN 27011-723), and to the **Frame Flange ALT FLX 915iS** (PN 26007-322) with 2x **M6x20 Hexagon Bolt** (PN 27007-371), 4x **M6 Washer** (PN 32012-022) and 2x **M6 Stop Nut** (PN 27011-723). Additionally connect the to the **Frame Crossbar ALT FLX 915iS** (PN 26007-319) to the Rotax Attachment Points **GR1** and **GL1** with the pre-installed bolts.
10. Tighten all bolts from steps 6-9 and torque them as specified in **Table 4-1**. Secure the **M10x20 Hexagon Bolt** (PN 27011-731) against the **Frame Flange Bank1 ALT FLX 915iS** (PN 26007-315)

with safety wire. Secure the 2x **M8x20 Hexagon Bolt** (PN 27011-729) against each other with safety wire.

11. Place the **Double-Pulley Engine 260mm 912iS/915iS** (PN 26007-312) behind the propeller flange. Place the 2x **Fixing Pulley** (PN 26001-870) between the **Double-Pulley Engine 260mm 912iS/915iS** (PN 26007-312) and the propeller flange. The fixing pulleys can be temporarily secured with 2x M10 bolts and 2x M10 nuts (not included) until the propeller is installed.
12. Mount the **Double-Pulley Engine 260mm 912iS/915iS** (PN 26007-312) on the 2x **Fixing Pulley** (PN 26001-870) with 8x **M6x20 Socket Head Bolt** (PN 30115-020) and 8x **M6 Washer** (PN 32012-022). Apply Loctite 243 on all 8x **M6x20 Socket Head Bolt** (PN 30115-020).
13. Apply battery terminal grease on all connections between the alternator and the bearings.
14. Mount one **Alternator ALT FLX** (PN 26001-862) between the **Frame Flange ALT FLX 915iS** (PN 26007-322) and the **Frame Strut ALT FLX 915iS** (PN 26001-872) by inserting 1x **UNF 7/16"-20 x 6" Hexagon Bolt** (PN 30006-422) with 1x **UNF 7/16"-20 Nut** (PN 44421-006), the **Distance Tube ALT FLX** (PN 26001-875) and 2x **M12 Locking Plates** (PN 32200-012) through the pivot hole of the alternator. Do not tighten the bolt yet.
15. Adjust the position in x-direction between the **Alternator ALT FLX** (PN 26001-862) and the frames using the **Shim Set Alternator** (PN 12-542). Ensure that the **Pulley Engine 260mm 912iS/915iS** (PN 26003-252) and the pre-mounted **Pulley ALT FLX 915iS** (PN 26001-877) are in the same plane for proper belt alignment. The assembly needs to fit tight between the **Frame Flange ALT FLX 915iS** (PN 26007-322) and the **Frame Strut ALT FLX 915iS** (PN 26001-872).
16. Place the other **Alternator ALT FLX** (PN 26001-862) between the **Frame Flange Bank1 ALT FLX 915iS** (PN 26007-315) and the **Frame Strut Bank1 ALT FLX 915iS** (PN 26007-316) by inserting 1x **UNF 7/16"-20 x 4" Hexagon Bolt** (PN 27007-507) with 1x **UNF 7/16"-20 Flat Nut** (PN 27007-506) and 2x **M12 Locking Plates** (PN 32200-012) through the pivot hole of the alternator. Do not tighten the bolt yet.
17. Adjust the position in x-direction between the **Alternator ALT FLX** (PN 26001-862) and the frames using the **Shim Set Alternator** (PN 12-54). Ensure that the **Double-Pulley Engine 260mm 912iS/915iS** (PN 26007-312) and the pre-mounted **Pulley ALT FLX 915iS** (PN 26001-877) are in the same plane for proper belt alignment. The assembly needs to fit tight between the **Frame Flange Bank1 ALT FLX 915iS** (PN 26007-315) and the **Frame Strut Bank1 ALT FLX 915iS** (PN 26007-316).
18. Mount one **V-Belt XPZ 962** (PN 26003-253) on the **Double-Pulley Engine 260mm 912iS/915iS** (PN 26007-312) and the pre-mounted **Pulley ALT FLX 912iS/ULS** (PN 26006-065) on Bank 2 side, and the other **V-Belt XPZ 962** (PN 26003-253) on the **Double-Pulley Engine 260mm 912iS/915iS** (PN 26007-312) and the pre-mounted **Pulley ALT FLX 912iS/ULS** (PN 26006-065) on Bank 1 side.
19. Mount the propeller as described in the propeller manual. The propeller bolts must be inserted through both the Rotax propeller shaft holes and the **Fixing Pulley** (PN 26001-870) mounting holes.
20. Move the **Alternator ALT FLX** (PN 26001-862) on Bank 2 side to tense the corresponding belt. Fix the position by inserting 1x **UNC 3/8"-16 x 3/4" Hexagon Bolt** (PN 27011-699) with 1x **M10 Washer** (PN 32010-010) through the slot of the **Frame Flange ALT FLX 912iS** (PN 26006-064) into the adjusting hole of the alternator. The belt will soften during the first few runs and

needs to be retightened. Use the **Shim Set Alternator** (PN 12-542) to align the alternator to the frames.

21. Tighten and torque the **UNC 3/8"-16 x 3/4" Hexagon Bolt** (PN 27011-699) as specified in **Table 4-1**. Secure it against the **Frame Flange ALT FLX 912iS** (PN 26006-064) with safety wire.
22. Tighten and torque the **UNF 7/16"-20 x 6" Hexagon Bolt** (PN 30006-422) as specified in **Table 4-1**. Bend the edges of the **M12 Locking Plates** (PN 32200-012) according to usual procedure to secure them.
23. Move the **Alternator ALT FLX** (PN 26001-862) on Bank 1 side to tense the corresponding belt. Fix the position by inserting 1x **UNC 3/8"-16 x 3/4" Hexagon Bolt** (PN 27011-699) with 1x **M10 Washer** (PN 32010-010) through the slot of the **Frame Flange Bank1 ALT FLX 912iS** (PN 27005-884) into the adjusting hole of the alternator. The belt will soften during the first few runs and needs to be retightened. Use the **Shim Set Alternator** (PN 12-542) to align the alternator to the frames.
24. Tighten and torque the **UNC 3/8"-16 x 3/4" Hexagon Bolt** (PN 27011-699) as specified in **Table 4-1**. Secure it against the **Frame Flange Bank1 ALT FLX 912iS** (PN 27005-884) with safety wire.
25. Tighten and torque the **UNF 7/16"-20 x 6" Hexagon Bolt** (PN 30006-422) as specified in **Table 4-1**. Bend the edges of the **M12 Locking Plates** (PN 32200-012) according to usual procedure to secure them.
26. Thoroughly check the complete installation.

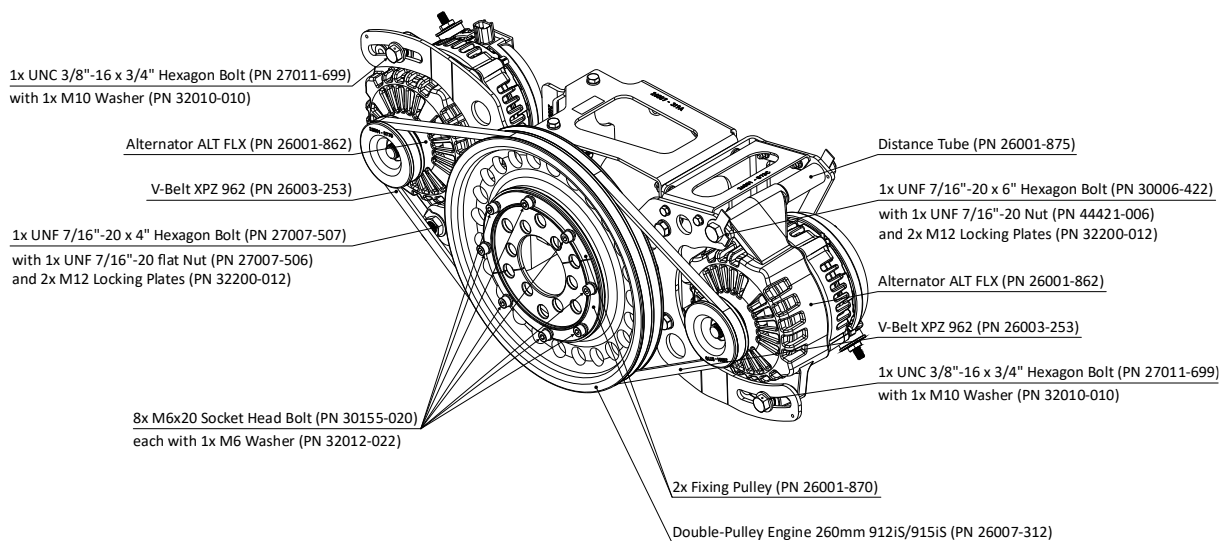

**Figure 5-17: Isometric View Ext. Double Alternator Kit 2x 150A Rotax 915iS**

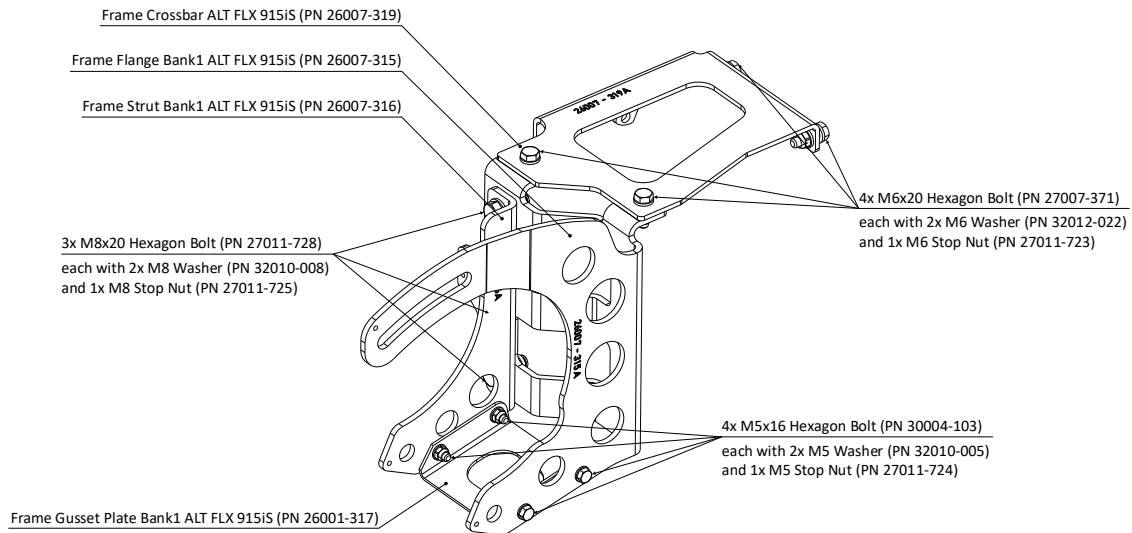

**Figure 5-18: Isometric View Ext. Double Alternator Kit 2x 150A Rotax 915iS Frames Bank1**

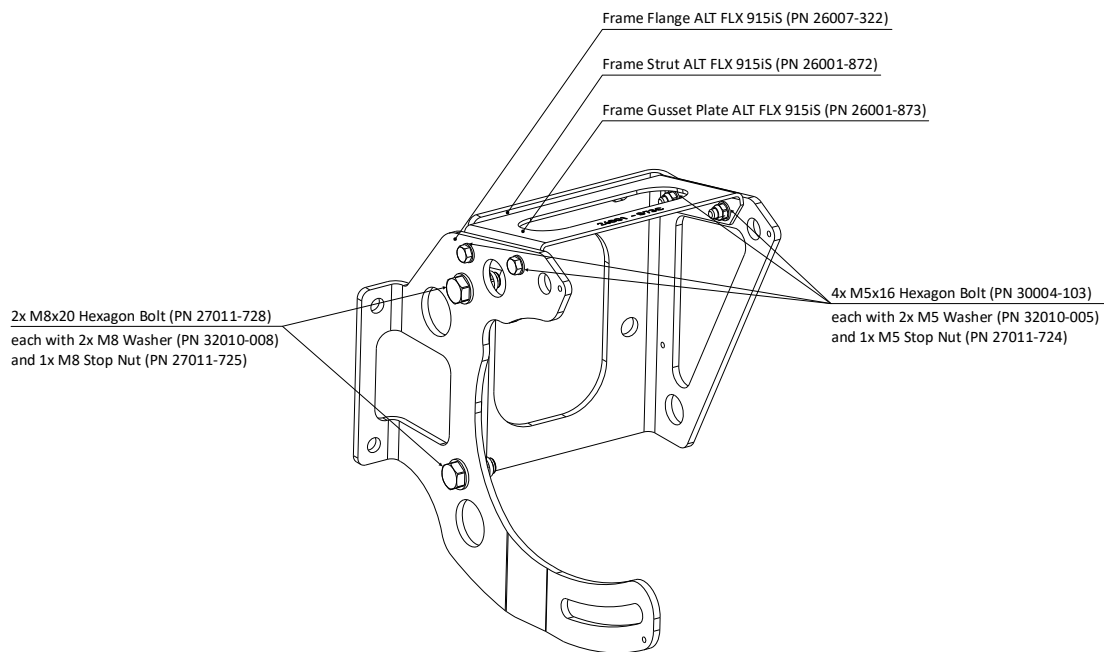

**Figure 5-19: Isometric View Ext. Double Alternator Kit 2x 150A Rotax 915iS Frames Bank2**

## 5.10 Assembly Instructions Ext. Double Alternator Kit 2x 150A Rotax 916iS

**PN Alternator Kit:** 12-192

**PN Mounting Kit:** 27011-811

1. Mount the **Frame Flange ALT FLX 915iS** (PN 26007-322) to the Rotax Attachment Points **L5** and **L6** with 2x **M8x20 Hexagon Bolt** (PN 27011-729) and 2x **M8 Washer** (PN 32010-008). Do not tighten the bolts yet.
2. Mount the **Frame Strut ALT FLX 915iS** (PN 26001-872) to the Rotax Attachment Point **L4** with 1x **M10x20 Hexagon Bolt** (PN 27011-731) and 1x **M10 Washer** (PN 32010-010). Do not tighten the bolt yet.
3. Connect the **Frame Flange ALT FLX 915iS** (PN 26007-322) and the **Frame Strut ALT FLX 915iS** (PN 26001-872) with 2x **M8x20 Hexagon Bolt** (PN 27011-728), 4x **M8 Washer** (PN 32010-008) and 2x **M8 Stop Nut** (PN 27011-725). Do not tighten the bolts yet.
4. Mount the **Frame Gusset Plate ALT FLX 915iS** (PN 26001-873) between the **Frame Flange ALT FLX 915iS** (PN 26007-322) and the **Frame Strut ALT FLX 915iS** (PN 26001-872) with 4x **M5x16 Hexagon Bolt** (PN 30004-103), 8x **M5 Washer** (PN 32010-005) and 4x **M5 Stop Nut** (PN 27011-724).
5. Tighten all bolts from steps 5.31-4 and torque them as specified in **Table 4-1**. Secure the **M10x20 Hexagon Bolt** (PN 27011-731) against the **Frame Strut ALT FLX 915iS** (PN 26001-872) with safety wire. Secure the 2x **M8x20 Hexagon Bolt** (PN 27011-729) against each other with safety wire.
6. Mount the **Frame Flange Bank1 ALT FLX 915iS** (PN 26007-315) to the Rotax Attachment Point **R4** with 1x **M10x20 Hexagon Bolt** (PN 27011-731) and 1x **M10 Washer** (PN 32010-010), and to the Rotax Attachment Points **R5** and **R6** with 2x **M8x20 Hexagon Bolt** (PN 27011-729) and 2x **M8 Washer** (PN 32010-008). Do not tighten the bolts yet.
7. Mount the **Frame Strut Bank1 ALT FLX 915iS** (PN 26007-316) to the **Frame Flange Bank1 ALT FLX 915iS** (PN 26007-315) with 3x **M8x20 Hexagon Bolt** (PN 27011-728), 6x **M8 Washer** (PN 32010-008) and 3x **M8 Stop Nut** (PN 27011-725). Do not tighten the bolts yet.
8. Mount the **Frame Gusset Plate Bank1 ALT FLX 915iS** (PN 26001-317) between the **Frame Flange Bank1 ALT FLX 915iS** (PN 26007-315) and the **Frame Strut Bank1 ALT FLX 915iS** (PN 26007-316) with 4x **M5x16 Hexagon Bolt** (PN 30004-103), 8x **M5 Washer** (PN 32010-005) and 4x **M5 Stop Nut** (PN 27011-724). Do not tighten the bolts yet.
9. Mount the **Frame Crossbar ALT FLX 915iS** (PN 26007-319) to the **Frame Flange Bank1 ALT FLX 915iS** (PN 26007-315) with 2x **M6x20 Hexagon Bolt** (PN 27007-371), 4x **M6 Washer** (PN 32012-022) and 2x **M6 Stop Nut** (PN 27011-723), and to the **Frame Flange ALT FLX 915iS** (PN 26007-322) with 2x **M6x20 Hexagon Bolt** (PN 27007-371), 4x **M6 Washer** (PN 32012-022) and 2x **M6 Stop Nut** (PN 27011-723). Additionally connect the to the **Frame Crossbar ALT FLX 915iS** (PN 26007-319) to the Rotax Attachment Points **GR1** and **GL1** with the pre-installed bolts.
10. Tighten all bolts from steps 6-9 and torque them as specified in **Table 4-1**. Secure the **M10x20 Hexagon Bolt** (PN 27011-731) against the **Frame Flange Bank1 ALT FLX 915iS** (PN 26007-315) with safety wire. Secure the 2x **M8x20 Hexagon Bolt** (PN 27011-729) against each other with safety wire.

11. Place the **Double-Pulley Engine 260mm 912iS/915iS** (PN 26007-312) behind the propeller flange. Place the 2x **Fixing Pulley 916iS** (PN 27005-829) between the **Double-Pulley Engine 260mm 912iS/915iS** (PN 26007-312) and the propeller flange. The fixing pulleys can be temporarily secured with 2x M10 bolts and 2x M10 nuts (not included) until the propeller is installed.
12. Mount the **Double-Pulley Engine 260mm 912iS/915iS** (PN 26007-312) on the 2x **Fixing Pulley 916iS** (PN 27005-829) with 8x **M6x20 Socket Head Bolt** (PN 30115-020) and 8x **M6 Washer** (PN 32012-022). Apply Loctite 243 on all 8x **M6x20 Socket Head Bolt** (PN 30115-020).
13. Apply battery terminal grease on all connections between the alternator and the bearings.
14. Mount one **Alternator ALT FLX** (PN 26001-862) between the **Frame Flange ALT FLX 915iS** (PN 26007-322) and the **Frame Strut ALT FLX 915iS** (PN 26001-872) by inserting 1x **UNF 7/16"-20 x 6" Hexagon Bolt** (PN 30006-422) with 1x **UNF 7/16"-20 Nut** (PN 44421-006), the **Distance Tube ALT FLX** (PN 26001-875) and 2x **M12 Locking Plates** (PN 32200-012) through the pivot hole of the alternator. Do not tighten the bolt yet.
15. Adjust the position in x-direction between the **Alternator ALT FLX** (PN 26001-862) and the frames using the **Shim Set Alternator** (PN 12-542). Ensure that the **Pulley Engine 260mm 912iS/915iS** (PN 26003-252) and the pre-mounted **Pulley ALT FLX 915iS** (PN 26001-877) are in the same plane for proper belt alignment. The assembly needs to fit tight between the **Frame Flange ALT FLX 915iS** (PN 26007-322) and the **Frame Strut ALT FLX 915iS** (PN 26001-872).
16. Place the other **Alternator ALT FLX** (PN 26001-862) between the **Frame Flange Bank1 ALT FLX 915iS** (PN 26007-315) and the **Frame Strut Bank1 ALT FLX 915iS** (PN 26007-316) by inserting 1x **UNF 7/16"-20 x 4" Hexagon Bolt** (PN 27007-507) with 1x **UNF 7/16"-20 Flat Nut** (PN 27007-506) and 2x **M12 Locking Plates** (PN 32200-012) through the pivot hole of the alternator. Do not tighten the bolt yet.
17. Adjust the position in x-direction between the **Alternator ALT FLX** (PN 26001-862) and the frames using the **Shim Set Alternator** (PN 12-542). Ensure that the **Double-Pulley Engine 260mm 912iS/915iS** (PN 26007-312) and the pre-mounted **Pulley ALT FLX 915iS** (PN 26001-877) are in the same plane for proper belt alignment. The assembly needs to fit tight between the **Frame Flange Bank1 ALT FLX 915iS** (PN 26007-315) and the **Frame Strut Bank1 ALT FLX 915iS** (PN 26007-316).
18. Mount one **V-Belt XPZ 962** (PN 26003-253) on the **Double-Pulley Engine 260mm 912iS/915iS** (PN 26007-312) and the pre-mounted **Pulley ALT FLX 912iS/ULS** (PN 26006-065) on Bank 2 side, and the other **V-Belt XPZ 962** (PN 26003-253) on the **Double-Pulley Engine 260mm 912iS/915iS** (PN 26007-312) and the pre-mounted **Pulley ALT FLX 912iS/ULS** (PN 26006-065) on Bank 1 side.
19. Mount the propeller as described in the propeller manual. The propeller bolts must be inserted through both the Rotax propeller shaft holes and the **Fixing Pulley 916iS** (PN 27005-829) mounting holes.
20. Move the **Alternator ALT FLX** (PN 26001-862) on Bank 2 side to tense the corresponding belt. Fix the position by inserting 1x **UNC 3/8"-16 x 3/4" Hexagon Bolt** (PN 27011-699) with 1x **M10 Washer** (PN 32010-010) through the slot of the **Frame Flange ALT FLX 912iS** (PN 26006-064) into the adjusting hole of the alternator. The belt will soften during the first few runs and

needs to be retightened. Use the **Shim Set Alternator** (PN 12-542) to align the alternator to the frames.

21. Tighten and torque the **UNC 3/8"-16 x 3/4" Hexagon Bolt** (PN 27011-699) as specified in **Table 4-1**. Secure it against the **Frame Flange ALT FLX 912iS** (PN 26006-064) with safety wire.
22. Tighten and torque the **UNF 7/16"-20 x 6" Hexagon Bolt** (PN 30006-422) as specified in **Table 4-1**. Bend the edges of the **M12 Locking Plates** (PN 32200-012) according to usual procedure to secure them.
23. Move the **Alternator ALT FLX** (PN 26001-862) on Bank 1 side to tense the corresponding belt. Fix the position by inserting 1x **UNC 3/8"-16 x 3/4" Hexagon Bolt** (PN 27011-699) with 1x **M10 Washer** (PN 32010-010) through the slot of the **Frame Flange Bank1 ALT FLX 912iS** (PN 27005-884) into the adjusting hole of the alternator. The belt will soften during the first few runs and needs to be retightened. Use the **Shim Set Alternator** (PN 12-542) to align the alternator to the frames.
24. Tighten and torque the **UNC 3/8"-16 x 3/4" Hexagon Bolt** (PN 27011-699) as specified in **Table 4-1**. Secure it against the **Frame Flange Bank1 ALT FLX 912iS** (PN 27005-884) with safety wire.
25. Tighten and torque the **UNF 7/16"-20 x 6" Hexagon Bolt** (PN 30006-422) as specified in **Table 4-1**. Bend the edges of the **M12 Locking Plates** (PN 32200-012) according to usual procedure to secure them.
26. Thoroughly check the complete installation.

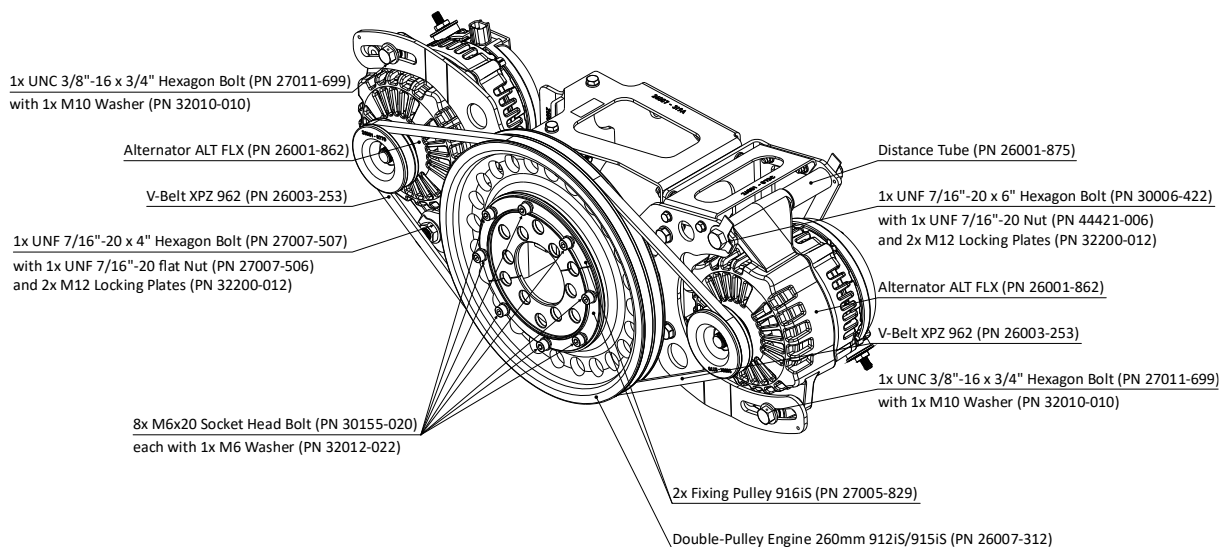

**Figure 5-20: Isometric View Ext. Double Alternator Kit 2x 150A Rotax 916iS**

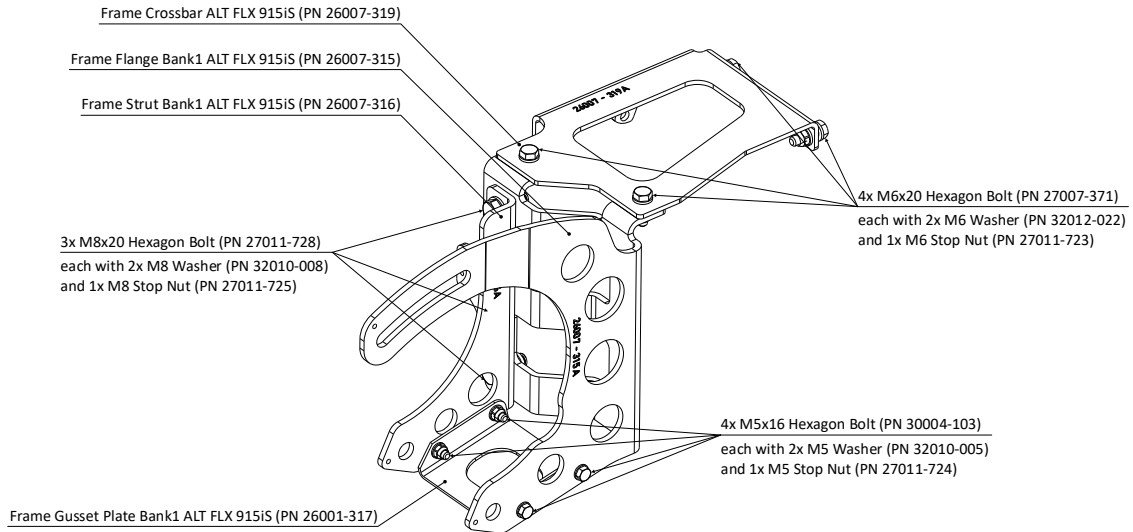

**Figure 5-21: Isometric View Ext. Double Alternator Kit 2x 150A Rotax 916iS Frames Bank1**

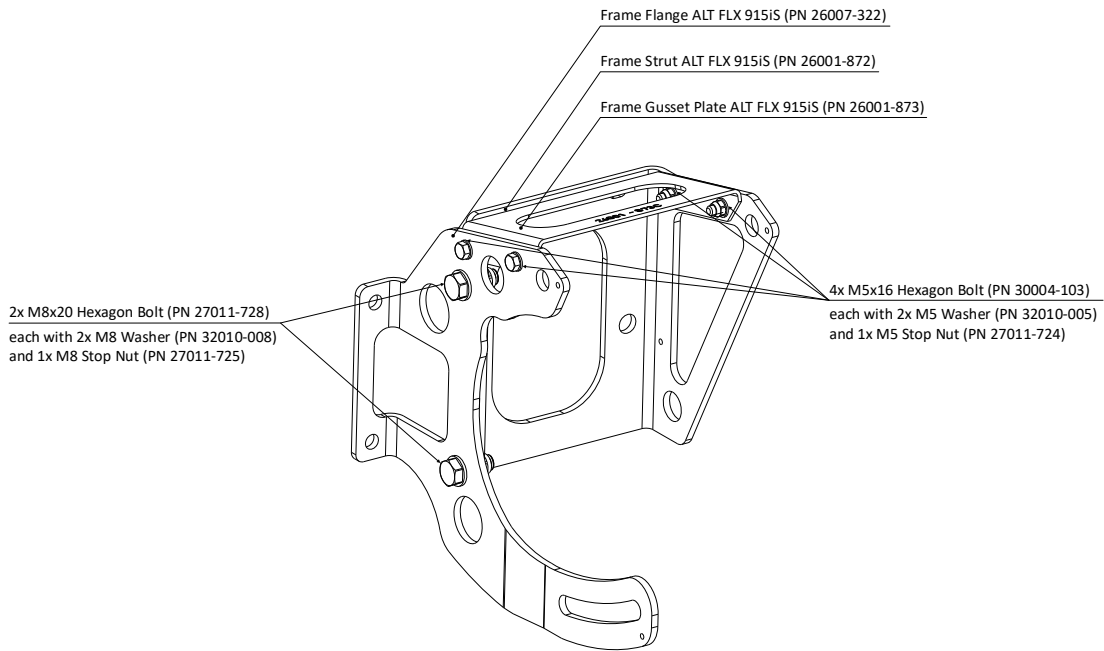
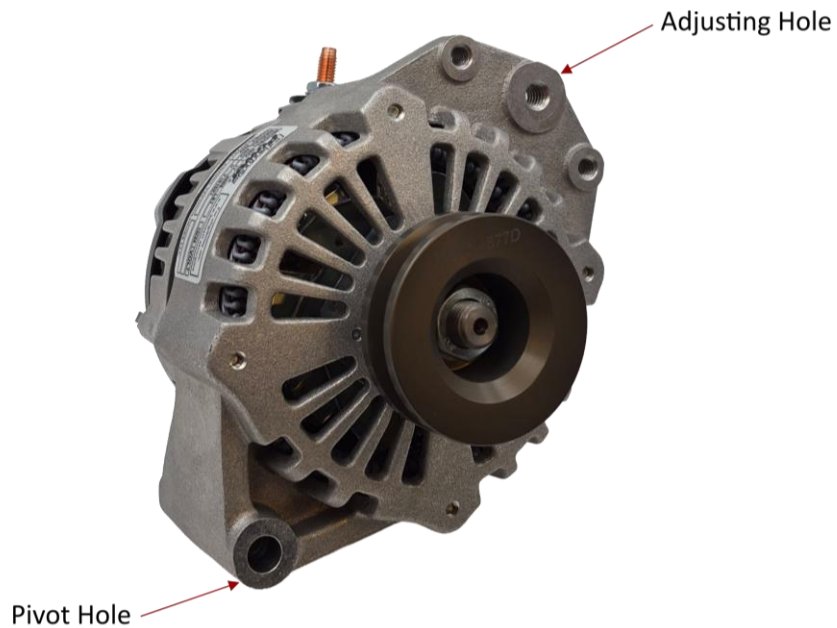

**Figure 5-22: Isometric View Ext. Double Alternator Kit 2x 150A Rotax 916iS Frames Bank2**

## 6. Electrical Installation and Operation

### 6.1 Electrical Installation Alternators 150A

The Alternator 150A must be installed with an R1224 Regulator as seen in **Figure 6-3** for single alternator use or in **Figure 6-4** for double alternator use.



**Figure 6-1: Mechanical Connection Points Alternator 150A**

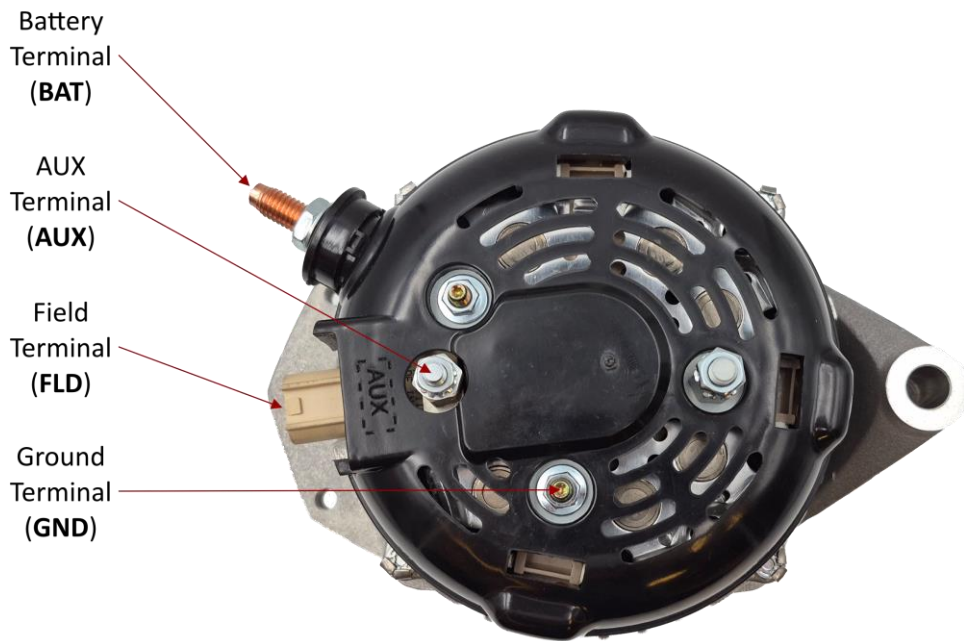

Figure 6-2: Electrical Connection Points Alternator 150A

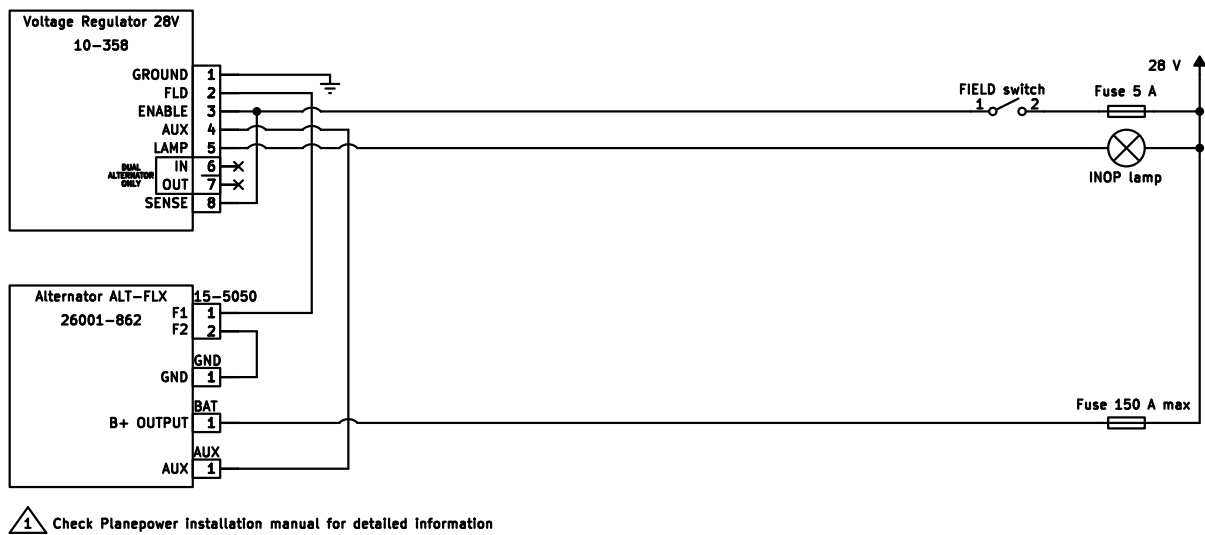
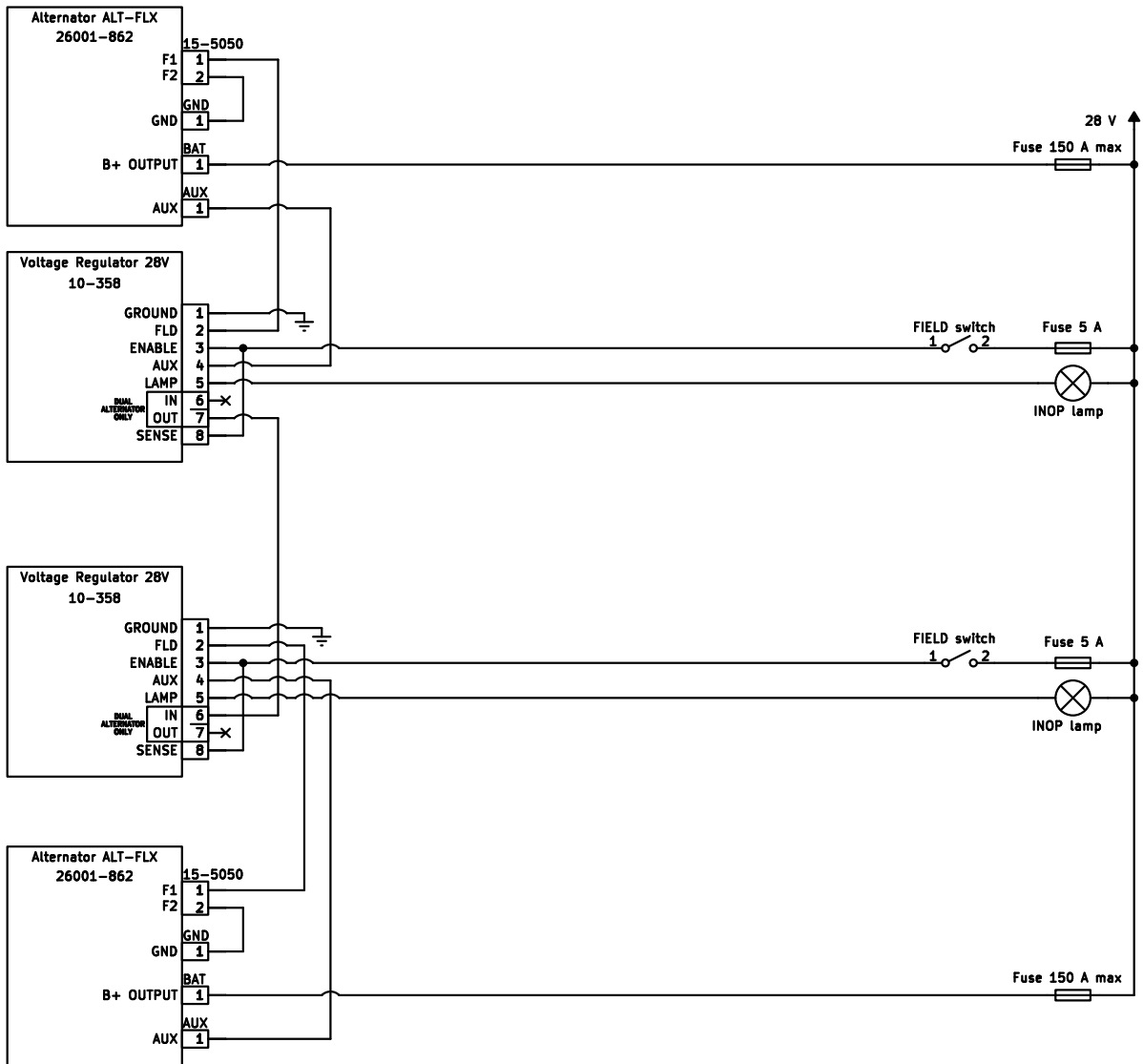

Figure 6-3: Wiring Diagram Single Alternator 150A



1 Check PlanePower installation manual for detailed information

Figure 6-4: Wiring Diagram Double Alternator 2x 150A

## 6.2 R1224 Regulator Installation

**Mechanical dimensions:** 120 mm x 70 mm x 24 mm

**Weight:** 257 g

For more information about the R1224 see Plane Power Document – R122a Regulator Installation Instructions.

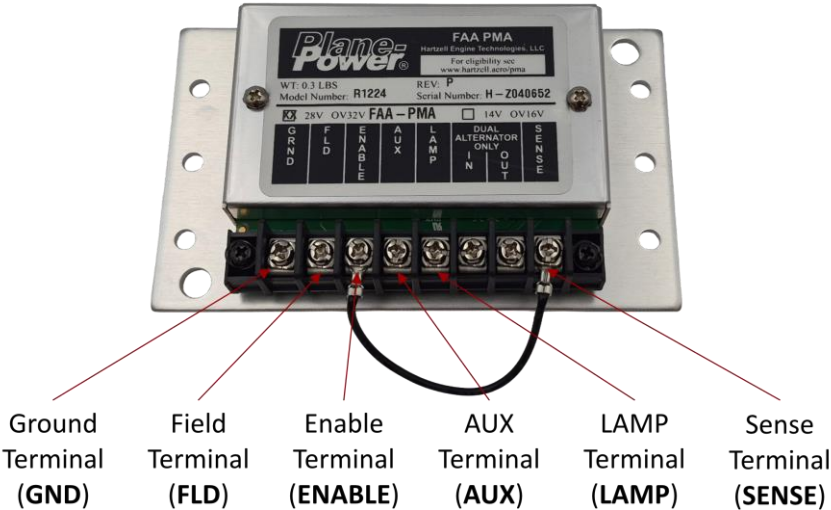

Figure 6-5: R1224 Regulator

## 7. Belt Tensioning

Tension the belt to the required value of 233 N.

To check if the belt has the required tension, use the **OPTIKRIK Optibelt V-Belt Tension Gauge** (PN 12-295) or the Optibelt TT Frequency measuring device. If the required value is not reached, loosen the **UNC 3/8"-16 x 3/4" Hexagon Bolt** (PN 27011-699) to retighten the belt and measure again.

## 8. Performance Charts

### 8.1 Performance Chart Ext. Alternator Kit 150A Rotax 912iS

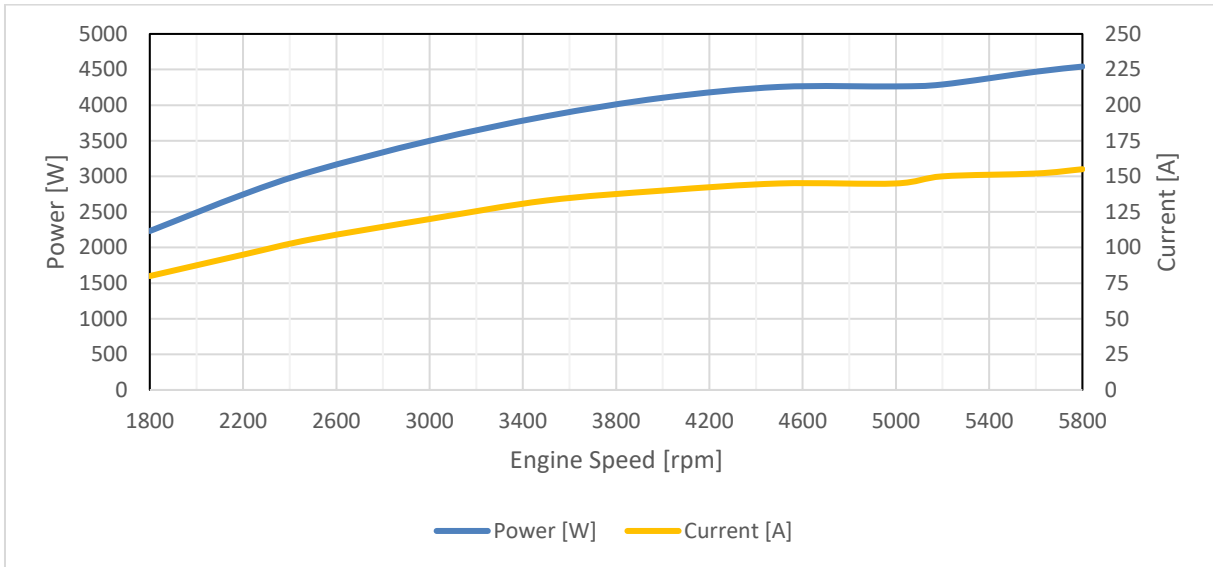

Figure 8-1: Performance over Engine Speed 150A Rotax 912iS

### 8.2 Performance Chart Ext. Double Alternator Kit 2x 150A Rotax 912iS

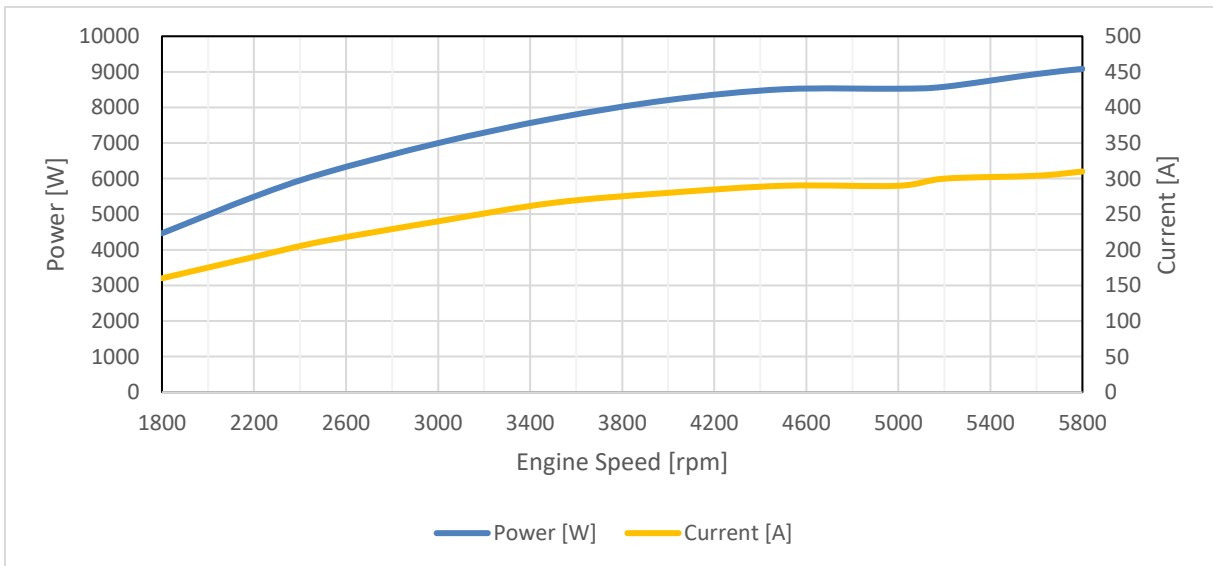

Figure 8-2: Performance over Engine Speed 2x 150A Rotax 912iS

### 8.3 Performance Chart Ext. Alternator Kit 150A Rotax 915iS

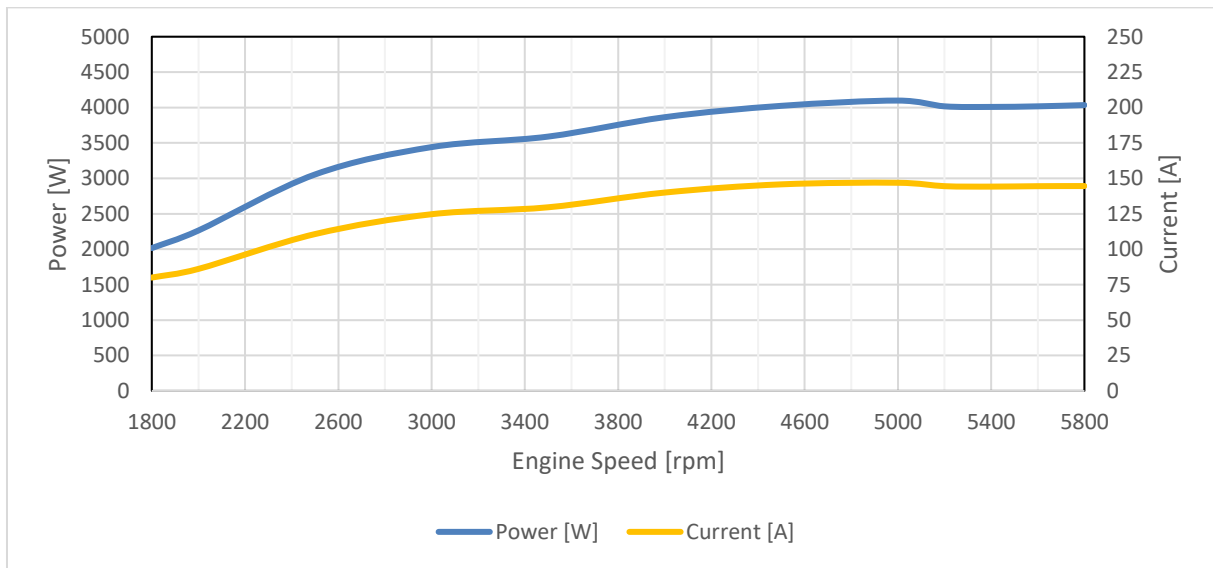

Figure 8-3: Performance over Engine Speed 150A Rotax 915iS

### 8.4 Performance Chart Ext. Double Alternator Kit 2x 150A Rotax 915iS

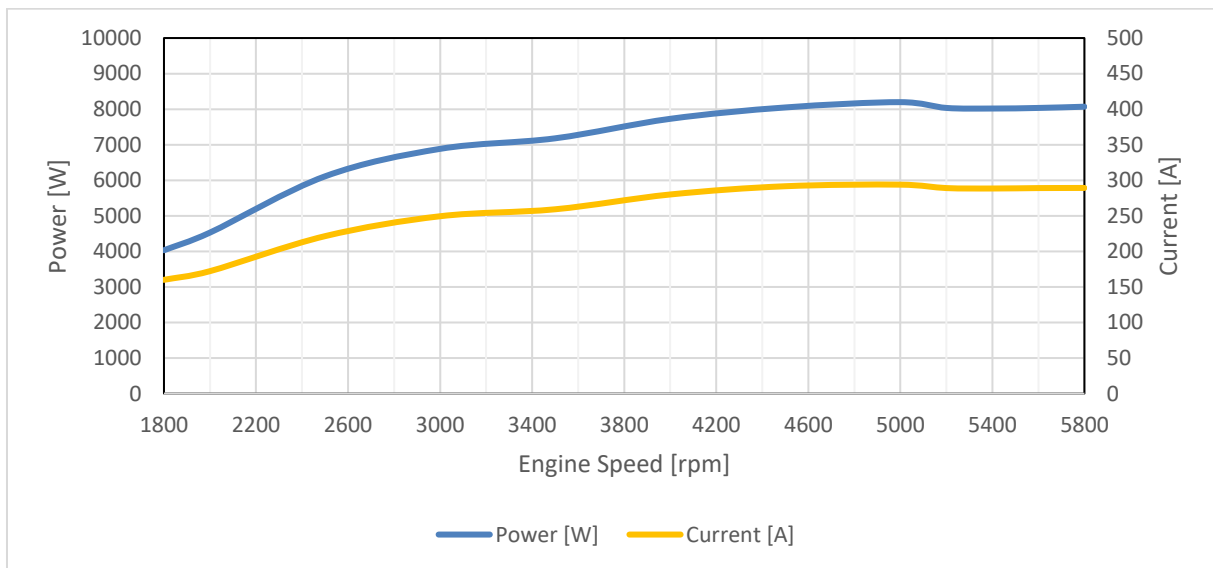

Figure 8-4: Performance over Engine Speed 2x 150A Rotax 915iS

End of Document.



RS Flight Systems GmbH

Oberer Luessbach 29-31

82335 Berg | Germany

+49 8178 8681 – 300

[contact@rs-flightsystems.com](mailto:contact@rs-flightsystems.com)

[www.rs-flightsystems.com](http://www.rs-flightsystems.com)

External Alternator Series 150A for BRP Rotax Aircraft Engines | Issue 4.0

© Copyright 2026 RS Flight Systems GmbH