

Installation / Operation Manual

External Alternator Series for BRP Rotax Aircraft Engines

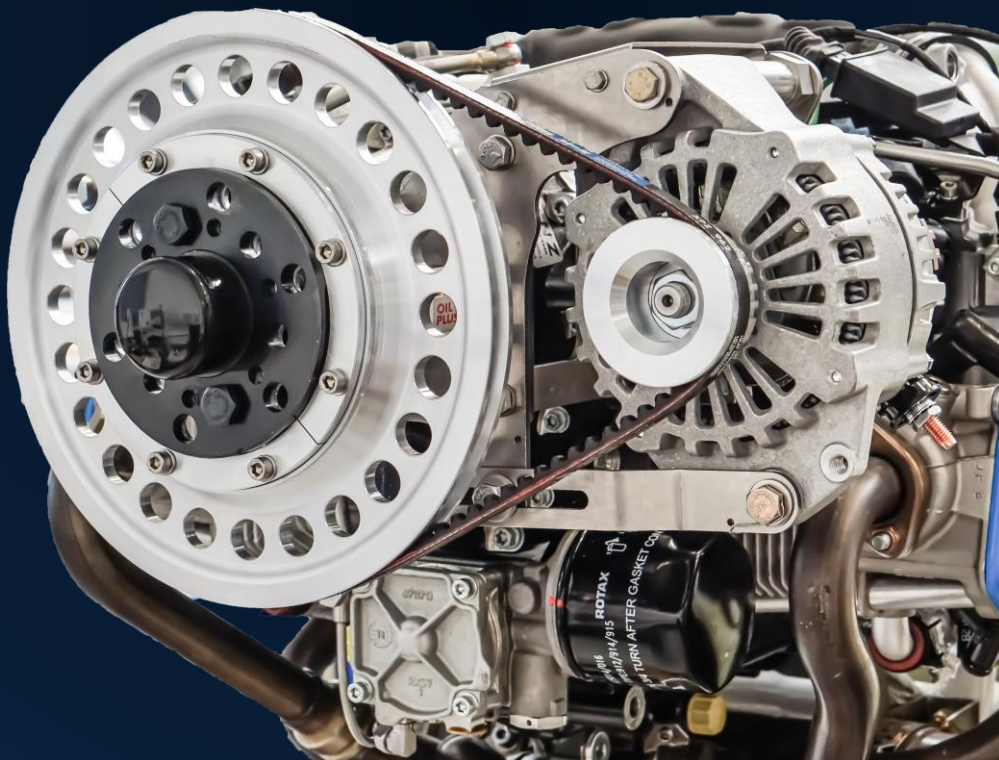

Contents

.....	1
1. Preface.....	3
2. System Description.....	3
3. Technical Specifications Overview	5
4. Mechanical Installation	6
4.1 Overview	6
4.2 Assembly Instructions 20A 912iS	7
4.3 Assembly Instructions 70A 912iS	9
4.4 Assembly Instructions 150A 912iS	11
4.5 Assembly Instructions 20A 915iS	13
4.6 Assembly Instructions 70A 915iS	15
4.7 Assembly Instructions 150A 915iS	17
4.8 Additional Drawings and Tables	21
5. Electrical Installation and Operation	24
5.1 Electrical Installation for all 150A Alternators	24
5.2 Electrical Installation for all 7A Alternators	26
5.3 Electrical Installation for all 20A Alternators	28
5.4 R1224 Regulator Installation	30
6. Performance Charts	31
6.1 Performance Chart 20A 912iS.....	31
6.2 Performance Chart 70A 912iS.....	31
6.3 Performance Chart 912iS 150 A.....	32
6.4 Performance Chart 915iS 20 A.....	32
6.5 Performance Chart 70A 915iS.....	33
6.6 Performance Chart 150A 915iS.....	33
6.7 Performance Chart 300A 915iS.....	34

1. Preface

Thank you for purchasing an RS Flight Systems External Alternator Kit. We are pleased that you have chosen our product and are confident that it will meet all your expectations. In case of questions or problems with the unit, feel free to contact us:

RS Flight Systems GmbH
Oberer Luessbach 29-31
82335 Berg | Germany
Phone: +49-8178-8681-300
E-Mail: contact@rs-flightsystems.com

2. System Description

The series of External Alternators for the Rotax iS engine series comprises of several systems:

1. 20 A version for the 912 / 912S / 914 / 912iS
2. 70 A version for the 912 / 912S / 914 / 912iS
3. 150 A version for the 912 / 912S / 914 / 912iS
4. 20 A version for the 915iS / 916iS
5. 70 A version for the 915iS / 916iS
6. 150 A version for the 915iS / 916iS
7. 300 A double alternator for the 914 / 912iS
8. 300 A double alternator for the 915iS / 916iS

The 70A and 150A systems can be operated in 14 VDC and 28 VDC mode, the 20A systems can be operated in 28 VDC only. The system is fitted with special transmission ratio to achieve about 50 % of the nominal power at idle (1800 rpm). Above 4000 rpm (crankshaft) the full power is available. The high-performance belt drive and the Hartzell Alternators lead to a high system efficiency of roughly 75 %. The External Alternator 150 A for the 915iS is exemplary for all alternator kits shown in Figure 2-1 and Figure 2-2. The alternator is always mounted to the original Rotax mounting points on the left-hand side of the engines gear box (or in case of the 300A Alternator Kit on both sides). The pulley on the propeller shaft is mounted with adapters behind the propeller flange. The adapters are mounted in parallel with the propeller bolts.

The versions for the 912 / 912S / 914 / 912iS are referred to as 912iS in the following.

The versions for the 915iS / 916iS are referred to as 915iS in the following.

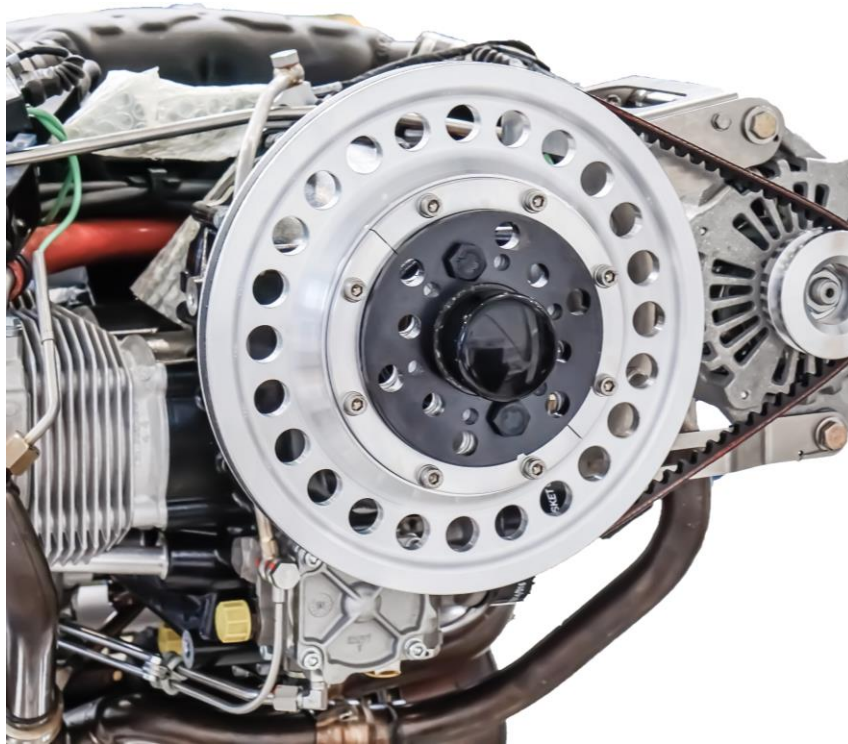

Figure 2-1: 150 A (4 kW) Ext. Alternator 915iS

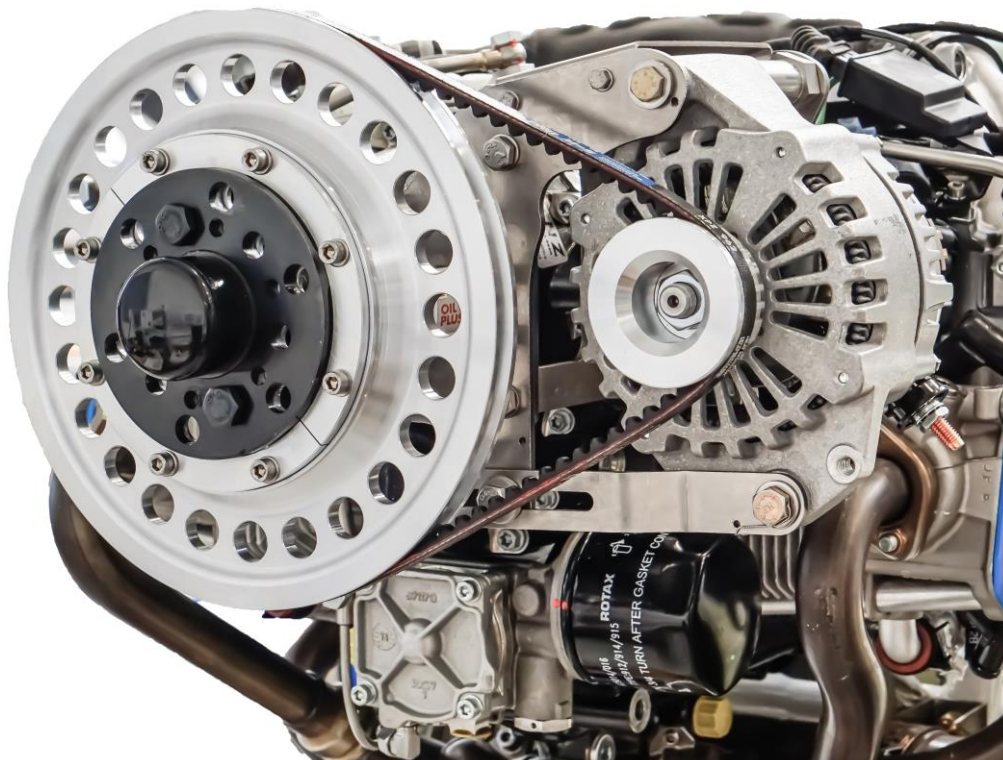

Figure 2-2: 150 A (4 kW) Ext. Alternator 915iS

3. Technical Specifications Overview

The technical specifications of the Ext. Alternators for the Rotax iS Series are listed in Table 3-1.

	20 A 912iS	70 A 912iS	150 A 912iS	20A 915iS	70 A 915iS	150 A 915iS	300 A 912iS	300 A 915iS
Mounting	Lefthand side Gearbox	Lefthand side Gearbox	Lefthand side Gearbox	Lefthand side Gearbox	Lefthand side Gearbox	Lefthand side Gearbox	Lefthand and Righthand side	Lefthand and Righthand side
Total Mass (Incl. Mounting Kit)	5.4 kg / 11.9 lb	6.3 kg / 13.9 lb	8.8 kg / 19.4 lb	5.2 kg / 11.5 lb	5.9 kg / 13.0 lb	8.7 kg / 19.2 lb	17.8 kg / 39.2 lb	17.8 kg / 39.2 lb
Maximum Current	20 A	70 A	150 A	20 A	70 A	150 A	300 A	300 A
Maximum Power	0.5 kW	2.0 kW	4.0 kW	0.5 kW	2.0 kW	4.0 kW	8.0 kW	8.0 kW
Maximum Voltage	28 VDC	28 VDC (14 VDC config)	28 VDC (14 VDC config)	28 VDC	28 VDC (14 VDC config)	28 VDC (14 VDC config)	28 VDC (14 VDC config)	28 VDC (14 VDC config)
Max Operating Temperature	up to +240° F/ up to + 116° C							
Belt Tension	233 N (Equals a force of 25 N when belt is pushed down 3.63 mm while mounted)							

Table 3-1: Technical specification

The versions for the 912 / 912S / 914 / 912iS are listed in this document with 912iS only.

4. Mechanical Installation

4.1 Overview

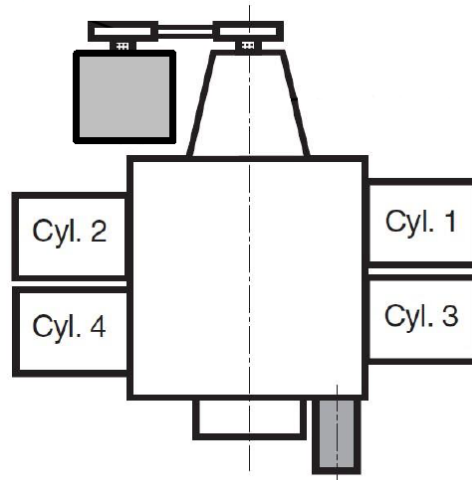

Figure 4-1: Layout Overview Single Generator

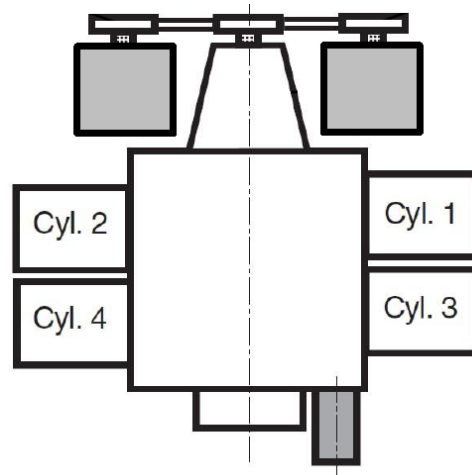

Figure 4-2: Layout Overview Double Generator

System sketches of the possible mounting layouts are shown in Figure 4-1 and Figure 4-2 .

4.2 Assembly Instructions 20A 912iS

1. Preassemble the **Mounting Frame** (PN 26006-073) with 2x **M8x18 Hexagon Screws** (PN 30006-384) and 2x **M8 Washer** (PN 32010-008) to the Rotax Attachment points L5 and L6 and with **M10x18 Screw** (PN 30006-385) and **M10 Washer** (PN 32010-010) to the Rotax Attachment point L4. Do not tighten the screws yet.
2. Mount the **Bracket** (PN 26006-075) onto the corresponding screw of the gear box housing. Use the screw that is already installed. Then, connect the **Bracket** (PN 26006-075) to the **Mounting Frame** (PN 26006-073) using 2x **M6x20 Hexagon Screw** (PN 30005-020), 4x **M6 Washer** (PN 32012-022) and 2x **M6 Stop Nut** (PN 31500-006). Do not tighten the screws yet.
3. Tighten all screws from step 1-2. Secure the **M10x18 Hexagon Screw** (PN 30006-385) with safety wire against the **Mounting Frame** (PN 26006-073). Safe the 2x **M8x18 Hexagon Screws** (PN 30006-384) with safety wire against each other.
4. Place the **Pulley Engine Side** (PN 26003-252) behind the propeller flange. Mount the 2x **Fixing Pulley** (PN 26001-870) behind the propeller flange with 2x **M10x20 Socket Head Screw** (PN 30117-105). This mounting is temporary and will be replaced by the bolts of the propeller later.
5. Mount the **Pulley Engine Side** (PN 26005-934) on the 2x **Fixing Pulley** (PN 26001-870) with 8x **M6x14 Socket Head Screw** (PN 30115-134) and 8x **M6 Washer** (PN 32012-022). Apply Loctite 243 on all 8x **M6x14 Socket Head Screw** (PN 30115-134).
6. Apply battery terminal grease on all connections between the alternator and the Mounting Frame
7. Place the Alternator in between the Mounting Frame Flanges with the **M10x30 Hexagon Screw** (PN 30006-135), **M10x50 Hexagon Screw** (PN 30006-139), 2x **M10 Stop Nuts** (PN 31000-010), **Distance Tube** (PN 26006-074) and 4x **M10 Locking Plates** (PN 32200-011). Adjust the position in x-direction with the **D10 Shim Rings** between the alternator and the Side Frames. The plane of the **Pulley Engine Side** (PN 26003-252) and the Pulley Generator Side must be equal. The assembly needs to fit tight between the **Mounting Frame** (PN 26006-073) Flanges.
8. Mount the **Belt** (PN 26003-077) on both pulleys.
9. Mount the propeller as described in the propeller manual.
10. Move the alternator to tension the belt. The belt will soften at the first runs and needs to be retightened. Fix the position by tightening the **M8x18 Hexagon Screw** (PN 30006-384) on the **Mounting Frame** (PN 26006-073). Tighten and secure the **M8x18 Hexagon Screw** (PN 30006-384) against the **Mounting Frame** (PN 26006-073) with safety wire.
11. Tighten the **M10x30 Hexagon Screw** (PN 30006-135), **M10x50 Hexagon Screw** (PN 30006-139) and bend the edges of the **M10 Locking Plates** (PN 32200-011) according to usual procedure to secure them.
12. Torque all screws to specified values as seen in Table 4-1 .
13. Thoroughly check the complete installation.

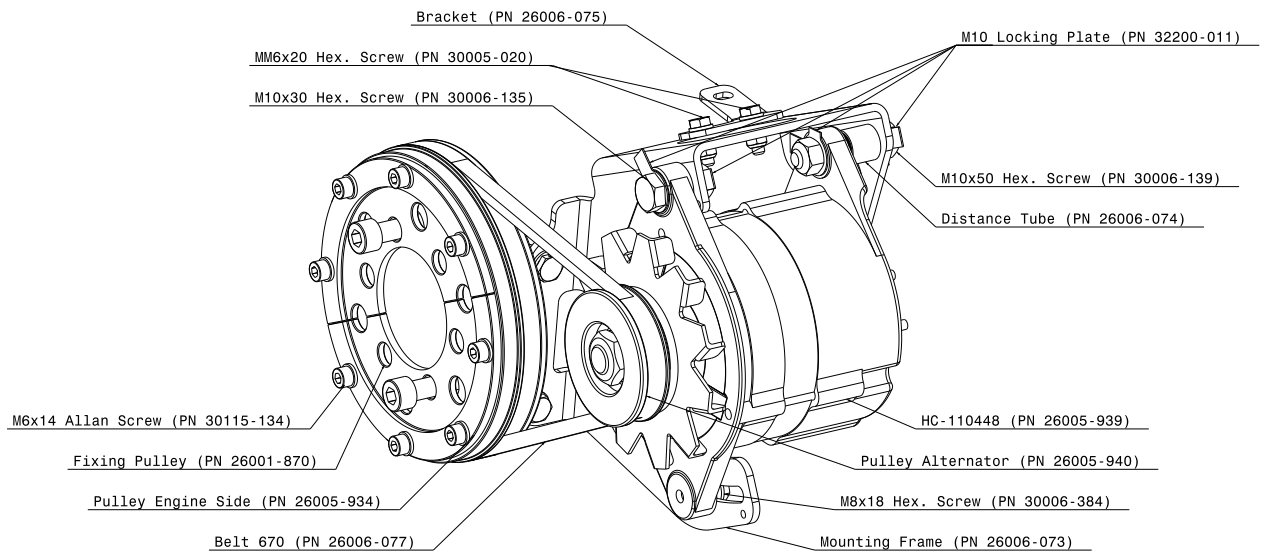

Figure 4-3 : Isometric view 20A 912iS

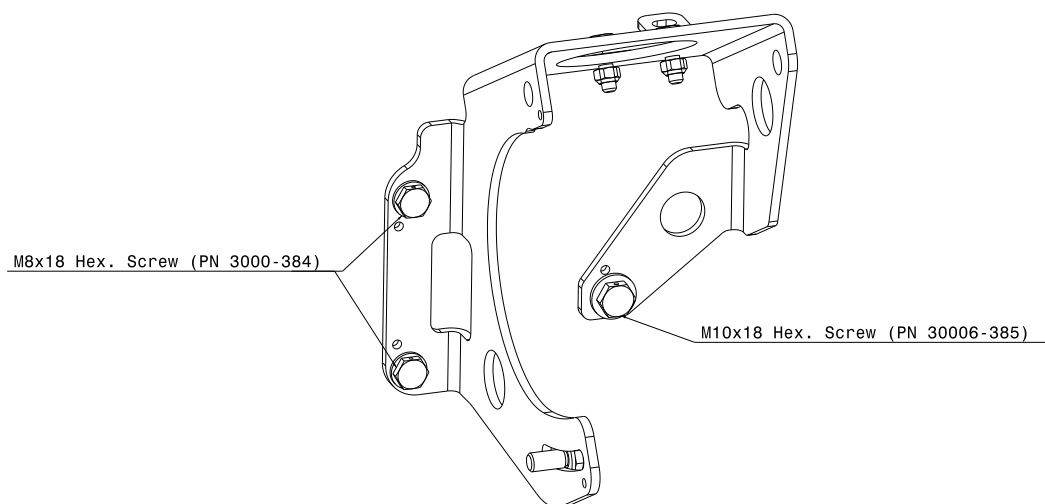

Figure 4-4 : Isometric view Mounting Frame 20A 912iS

4.3 Assembly Instructions 70A 912iS

1. Preassemble the **Side Frame LH** (PN 26006-054) with 2x **M8x18 Hexagon Screws** (PN 30006-384) and 2x **M8 Washer** (PN 32010-008) to the Rotax Attachment points L5 and L6. Do not tighten the screws yet.
2. Preassemble the **Side Frame RH** (PN 26006-053) with **M10x18 Screw** (PN 30006-385) and **M10 Washer** (PN 32010-010) to the Rotax Attachment point L4. Do not tighten the screw yet.
3. Connect the **Side Frame LH** (PN 26006-054) and the **Side Frame RH** (PN 26006-053) with 2x **M6x20 Hexagon Screw** (PN 30005-020), 4x **M6 Washer** (PN 32012-022) and 2x **M6 Stop Nut** (PN 31500-006). Do not tighten the screws yet.
4. Mount the **Bracket** (PN 26006-068) onto the two corresponding screws of the gear box housing. Use the screws that are already installed. Then, connect the **Bracket** (PN 26006-068) to the **Side Frame RH** (PN 26006-053) using 2x **M6x20 Hexagon Screw** (PN 30005-020), 4x **M6 Washer** (PN 32012-022) and 2x **M6 Stop Nut** (PN 31500-006). Do not tighten the screws yet.
5. Install the **Connecting Bracket** (PN 26006-079) in between the two Side Frames with 4x **M5x16 Hexagon Screws** (PN 300004-103), 8x **M6 Washer** (PN 32010-005) and 4x **M6 Stop Nut** (PN 31500-005).
6. Tighten all screws from step 1-5. Secure the **M10x18 Hexagon Screw** (PN 30006-385) with safety wire against the **Side Frame RH** (PN 26001-872). Safe the 2x **M8x18 Hexagon Screws** (PN 30006-384) with safety wire against each other.
7. Place the **Pulley Engine Side** (PN 26003-252) behind the propeller flange. Mount the 2x **Fixing Pulley** (PN 26001-870) behind the propeller flange with 2x **M10x20 Socket Head Screw** (PN 30117-105). This mounting is temporary and will be replaced by the bolts of the propeller later.
8. Mount the **Pulley Engine Side** (PN 26003-252) on the 2x **Fixing Pulley** (PN 26001-870) with 8x **M6x20 Socket Head Screw** (PN 30115-020) and 8x **M6 Washer** (PN 32012-022). Apply Loctite 243 on all 8x **M6x20 Socket Head Screw** (PN 30115-020).
9. Apply battery terminal grease on all connections between the alternator and the Side Frames
10. Place the Alternator in between the two Side Frames with the **UNF 7/16"-20 x4 1/2" Hexagon Screw** (PN 30006-423), **UNF 7/16"-20 Nut** (PN 44421-006) and two **M12 Locking Plates** (PN 32200-012). Adjust the position in x-direction with the **D12 Shim Ring** (PN 32062-006) between the alternator and the Side Frames. The plane of the **Pulley Engine Side** (PN 26003-252) and the Pulley Generator Side must be equal. The assembly needs to fit tight between the **Side Frame LH** (PN 26006-054) and the **Side Frame RH** (PN 26006-054).
11. Mount the Belt (PN 26003-253) on both pulleys.
12. Mount the propeller as described in the propeller manual.
13. Move the alternator to tension the belt. The belt will soften at the first runs and needs to be retightened. Fix the position by tightening the screw on the **Side Frame LH** (PN 26006-

- 054). Tighten and secure the **UNC 3/8"-16 x 3/4"** (PN 20006-387) against the **Side Frame LH** (PN 26006-054) with safety wire.
14. Tighten the **UNF 7/16"-20 x 4 1/2" Hexagon Screw** (PN 30006-423) and **UNF 7/16"-20 Nut** (PN 44421-006) and bend the edges of the **M12 Locking Plates** (PN 32200-012) according to usual procedure to secure them.
 15. Torque all screws to specified values as seen in Table 4-1 .
 16. Thoroughly check the complete installation.

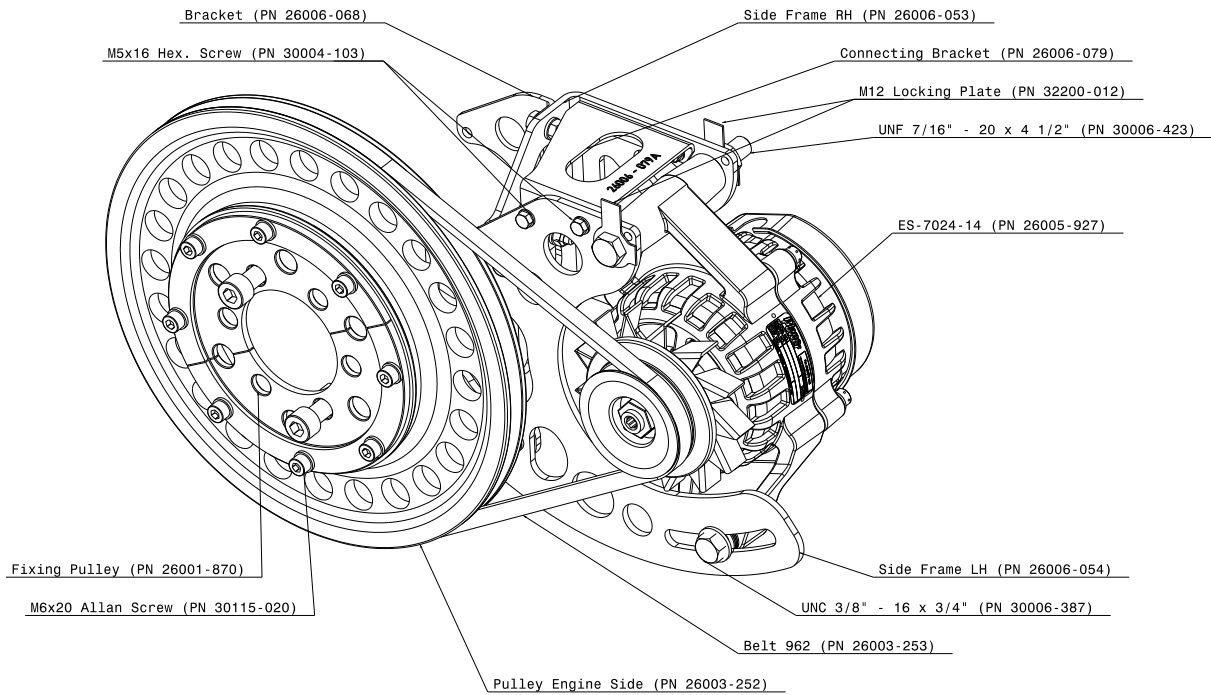

Figure 4-5 : Isometric view 70A 912iS

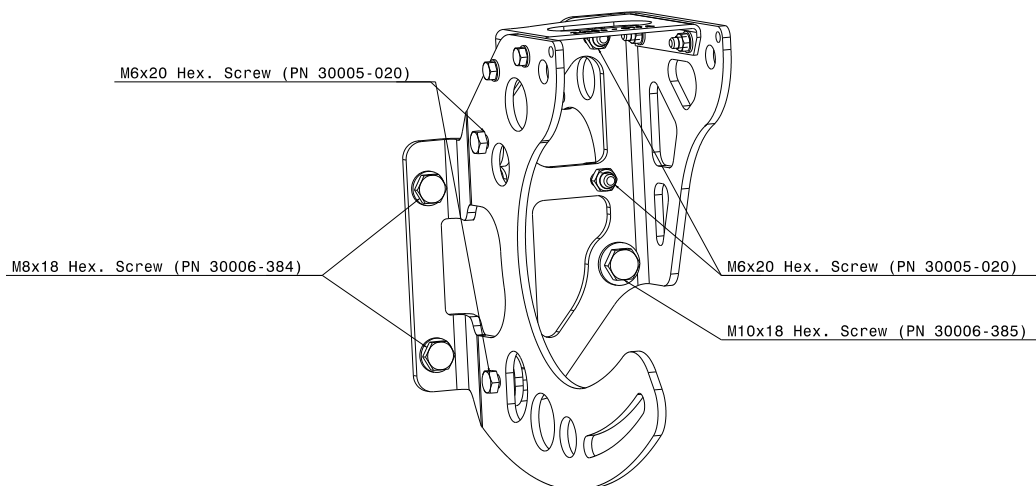

Figure 4-6 : Isometric view Side Frames 70A 912iS

4.4 Assembly Instructions 150A 912iS

1. Preassemble the **Side Frame LH** (PN 26006-064) with 2x **M8x18 Hexagon Screw** (PN 30006-384) and 2x **M8 Washer** (PN 32010-008) to the Rotax Attachment points L5 and L6. Do not tighten the screw yet.
2. Preassemble the **Side Frame RH** (PN 26006-063) with **M10x18 Hexagon Screw** (PN 30006-385) and **M10 Washer** (PN 32010-010) to the Rotax Attachment point L4. Do not tighten the screw yet.
3. Connect the **Side Frame LH** (PN 26006-064) and the **Side Frame RH** (PN 26006-063) with 3x **M6x20 Hexagon Screw** (PN 30005-020), 6x **M6 Washer** (PN 32012-022) and 3x **M6 Stop Nut** (PN 31500-006). Do not tighten the screws yet.
4. Mount the **Bracket** (PN 26006-068) onto the two corresponding screws of the gear box housing. Use the screws that are already installed. Then, connect the **Bracket** (PN 26006-068) to the **Side Frame RH** (PN 26006-053) using 2x **M6x20 Hexagon Screw** (PN 30005-020), 4x **M6 Washer** (PN 32012-022) and 2x **M6 Stop Nut** (PN 31500-006). Do not tighten the screws yet.
5. Install the **Connecting Bracket** (PN 26006-078) in between the two Side Frames with 4x **M5x16 Hexagon Screws**, 8x **M6 Washer** (PN 32010-005) and 4x **M6 Stop Nut** (PN 31500-005).
6. Tighten all screws from step 1-5. Safe the **M10x18 Hexagon Screw** (PN 30006-385) with safety wire against the **Side Frame RH** (PN 26001-872). Secure the 2x **M8x18 Hexagon Screw** (PN 30006-384) with safety wire against each other.
7. Place the **Pulley Engine Side** (PN 26003-252) behind the propeller flange. Mount the 2x **Fixing Pulley** (PN 26001-870) behind the propeller flange with 2x **M10x20 Allen Screw** (PN 30117-105). This mounting is temporary and will be replaced by the bolts of the propeller later.
8. Mount the **Pulley Engine Side** (PN 26003-252) on the 2x **Fixing Pulley** (PN 26001-870) with 8x **M6x20 Socket Head Screw** (PN 30115-020) and 8x **M6 Washer** (PN 32012-022). Apply Loctite 243 on all 8x **M6x20 Socket Head Screw** (PN 30115-020).
9. Apply battery terminal grease on all connections between the alternator and the Side Frames
10. Place the Alternator in between the two Side Frames with the **UNF 7/16"-20 x4 1/2" Hexagon Screw** (PN 30006-423), **UNF 7/16"-20 Nut** (PN 44421-006) and two **M12 Locking Plates** (PN 32200-012). Adjust the position in x-direction with the **D12 Shim Ring** (PN 32062-006) between the alternator and the Side Frames. The plane of the **Pulley Engine Side** (PN 26003-252) and the Pulley Generator Side must be equal. The assembly needs to fit tight between the **Side Frame LH** (PN 26006-064) and the **Side Frame RH** (PN 26006-063).
11. Mount the **Belt** (PN 26003-253) on both pulleys.
12. Mount the propeller as described in the propeller manual.
13. Move the alternator to tension the belt. The belt will soften at the first runs and needs to be retightened. Fix the position by tightening the screw on the **Side Frame LH** (PN 26006-

- 054). Tighten and secure the **UNC 3/8"-16 x 3/4"** (PN 20006-387) against the **Side Frame LH** (PN 26006-054) with safety wire.
14. Tighten the **UNF 7/16"-20 x 4 1/2" Hexagon Screw** (PN 30006-423) and **UNF 7/16"-20 Nut** (PN 44421-006) and bend the edges of the **M12 Locking Plates** (PN 32200-012) according to usual procedure to secure them.
 15. Torque all screws to specified values as seen in Table 4-1.
 16. Thoroughly check the complete installation.

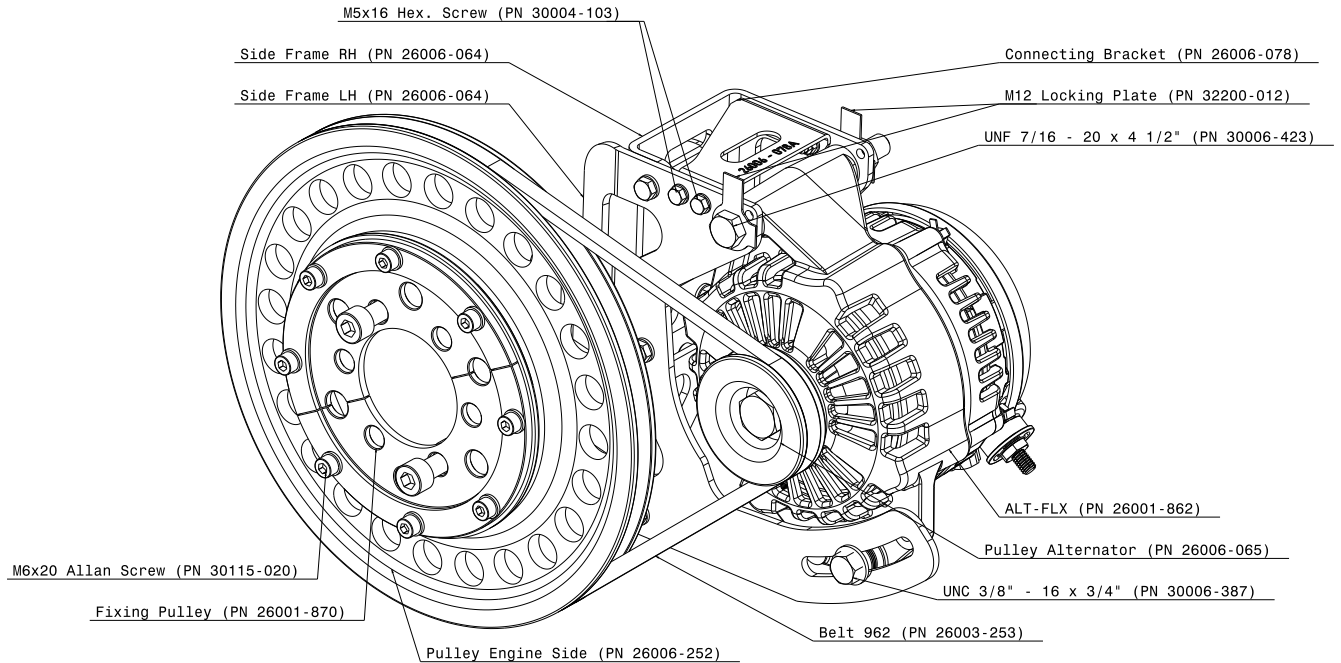

Figure 4-7 : Isometric view 150A 912iS

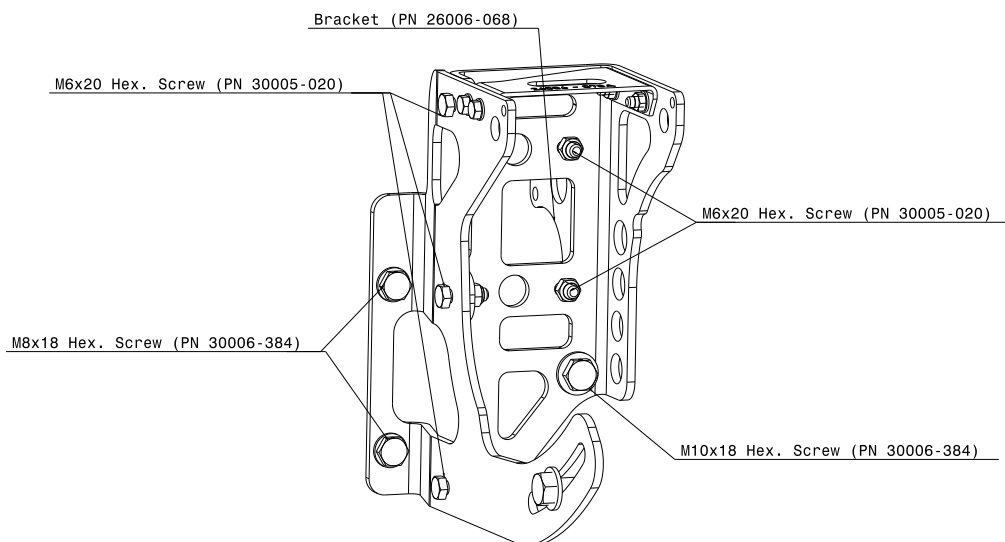

Figure 4-8 : Isometric view Side Frames 150A 912iS

4.5 Assembly Instructions 20A 915iS

1. Preassemble the **Mounting Frame** (PN 26005-933) with 2x **M8x18 Hexagon Screws** (PN 30006-384) and 2x **M8 Washer** (PN 32010-008) to the Rotax Attachment points L5 and L6 and with **M10x18 Screw** (PN 30006-385) and **M10 Washer** (PN 32010-010) to the Rotax Attachment point L4. Do not tighten the screws yet.
2. Mount the **Bracket** (PN 26005-937) onto the corresponding screw of the gear box housing. Use the screw that is already installed. Then, connect the **Bracket** (PN 26005-937) to the **Mounting Frame** (PN 26005-933) using a **M6x20 Hexagon Screw** (PN 30005-020), 2x **M6 Washer** (PN 32012-022) and 1x **M6 Stop Nut** (PN 31500-006). Do not tighten the screws yet.
3. Tighten all screws from step 1-2. Secure the **M10x18 Hexagon Screw** (PN 30006-385) with safety wire against the **Mounting Frame** (PN 26005-933). Safe the 2x **M8x18 Hexagon Screws** (PN 30006-384) with safety wire against each other.
4. Place the **Pulley Engine Side** (PN 26003-252) behind the propeller flange. Mount the 2x **Fixing Pulley** (PN 26001-870) behind the propeller flange with 2x **M10x20 Socket Head Screw** (PN 30117-105). This mounting is temporary and will be replaced by the bolts of the propeller later.
5. Mount the **Pulley Engine Side** (PN 26005-934) on the 2x **Fixing Pulley** (PN 26001-870) with 8x **M6x14 Socket Head Screw** (PN 30115-134) and 8x **M6 Washer** (PN 32012-022). Apply Loctite 243 on all 8x **M6x14 Socket Head Screw** (PN 30115-134).
6. Apply battery terminal grease on all connections between the alternator and the Mounting Frame
7. Place the Alternator in between the Mounting Frame Flanges with the **M10x30 Hexagon Screw** (PN 30006-135), **M10x65 Hexagon Screw** (PN 30006-142), 2x **M10 Stop Nuts** (PN 31000-010), **Distance Tube** (PN 26005-941) and 4x **M10 Locking Plates** (PN 32200-011). Adjust the position in x-direction with the **D10 Shim Rings** between the alternator and the Side Frames. The plane of the **Pulley Engine Side** (PN 26003-252) and the Pulley Generator Side must be equal. The assembly needs to fit tight between the **Mounting Frame** (PN 26005-933) Flanges.
8. Mount the **Belt** (PN 26005-948) on both pulleys.
9. Mount the propeller as described in the propeller manual.
10. Move the alternator to tension the belt. The belt will soften at the first runs and needs to be retightened. Fix the position by tightening the **M8x18 Hexagon Screw** (PN 30006-384) on the **Mounting Frame** (PN 26005-933). Tighten and secure the **M8x18 Hexagon Screw** (PN 30006-384) against the **Mounting Frame** (PN 26005-933) with safety wire.
11. Tighten the **M10x30 Hexagon Screw** (PN 30006-135), **M10x50 Hexagon Screw** (PN 30006-139) and bend the edges of the **M10 Locking Plates** (PN 32200-011) according to usual procedure to secure them.
12. Torque all screws to specified values as seen in Table 4-1 .
13. Thoroughly check the complete installation.

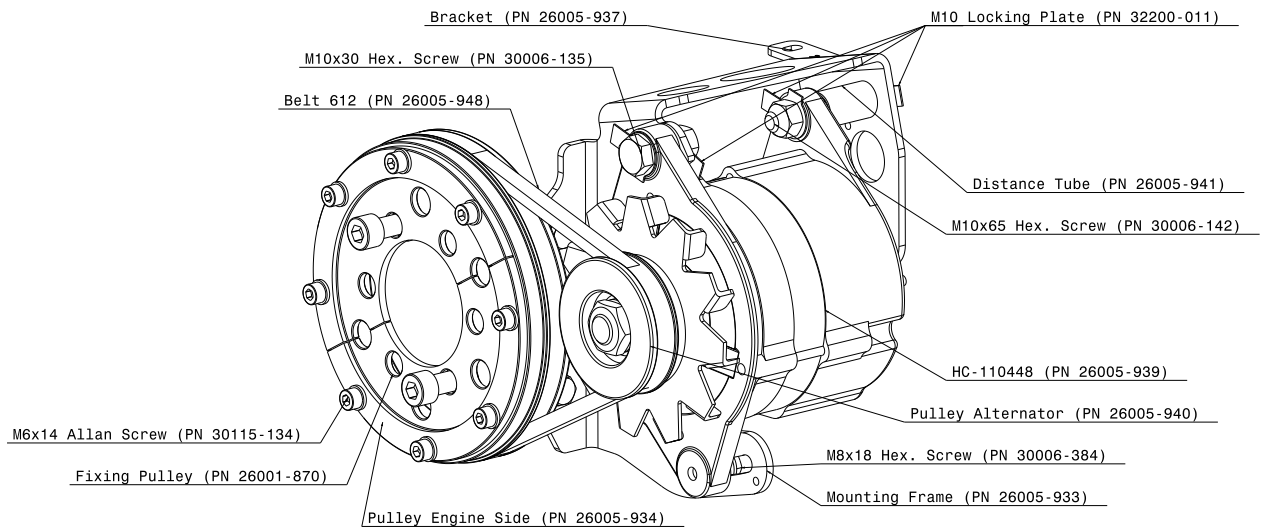

Figure 4-9 : Isometric view 20A 915iS

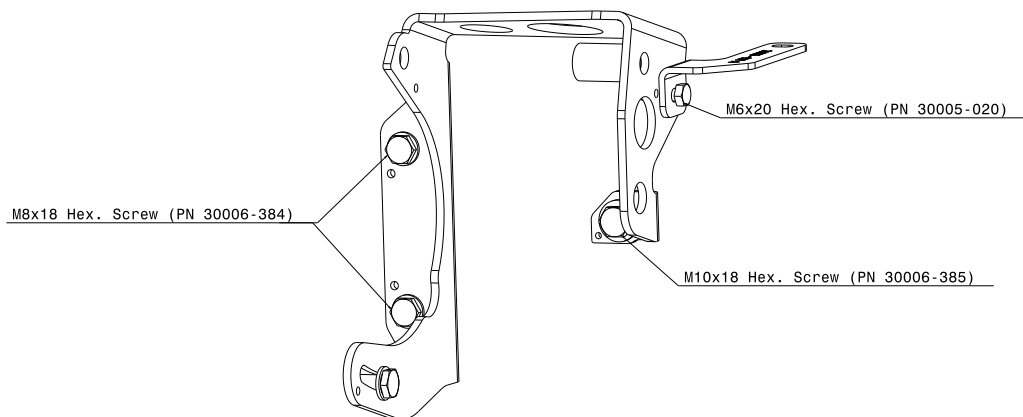

Figure 4-10 : Isometric view Mounting Frame 20A 915iS

4.6 Assembly Instructions 70A 915iS

1. Preassemble the **Side Frame** (PN 26003-923) with 2x **M8x18 Hexagon Screw** (PN 30006-384) and 2x **M8 Washer** (PN 32010-008) to the Rotax Attachment points L5 and L6 and to Attachment point L4 with **M10x18 Hexagon Screw** (PN 30006-385) and **M10 Washer** (PN 32010-010). Do not tighten the screw yet.
2. Tighten all screws from step 1. Secure the **M10x18 Hexagon Screw** (PN 30006-385) with safety wire against the **Side Frame** (PN 26001-872). Secure the 2x **M8x18 Hexagon Screw** (PN 30006-384) with safety wire against each other.
3. Place the **Pulley Engine Side** (PN 26003-252) behind the propeller flange. Mount the 2x **Fixing Pulley** (PN 26001-870) behind the propeller flange with 2x **M10x20 Socket Head Screw** (PN 30117-105). This mounting is temporary and will be replaced by the bolts of the propeller later.
4. Mount the **Pulley Engine Side** (PN 26003-252) on the 2x **Fixing Pulley** (PN 26001-870) with 8x **M6x20 Socket Head Screw** (PN 30115-020) and 8x **M6 Washer** (PN 32012-022). Apply Loctite 243 on all 8x **M6x20 Socket Head Screw** (PN 30115-020).
5. Apply battery terminal grease on all connections between the alternator and the bearings.
6. Place the Alternator in between the two mounting flanges of the Side Frame with the **UNF 7/16"-20 x 4 1/2" Hexagon Screw** (PN 30006-423), **UNF 7/16"-20 Nut** (PN 44421-006) and two **M12 Locking Plates** (PN 32200-012). Adjust the position in x-direction with the **D12 Shim Ring** (PN 32062-006) between the alternator and the Side Frames. The plane of the **Pulley Engine Side** (PN 26003-252) and the Pulley Generator Side must be equal. The assembly needs to fit tight between the Side Frame mounting flanges.
7. Mount the **Belt** (PN 26003-253) on both pulleys.
8. Mount the **Generator Strut** (PN 26005-925) to the alternator with **UNC 3/8"-16 x 3/4"** (PN 20006-387) and **M10 Washer** (PN 32012-010). Do not tighten the screw.
9. Mount the **Generator Strut** (PN 26001-876) on the **Side Frame** (PN 26005-923) with **M8x18 Hexagon Screw** (PN 30006-384), **M8 Thick Washer** (PN 32051-009).
10. Mount the propeller as described in the propeller manual.
11. Move the alternator to tension the belt. The belt will soften at the first runs and needs to be retightened. Fix the position by tightening the screws on the **Generator Strut** (PN 26001-876). Secure the **UNC 3/8"-16 x 3/4"** (PN 20006-387) against the **Generator Strut** (PN 26001-876) with safety wire.
12. Tighten the **7/16"-20 x 4 1/2" Hexagon Screw** (PN 30006-423) and **UNF 7/16"-20 Nut** (PN 44421-006) and bend the edges of the **M12 Locking Plates** (PN 32200-012) according to usual procedure to secure them.
13. Torque all screws to specified values as seen in Table 4-1.
14. Thoroughly check the complete installation.

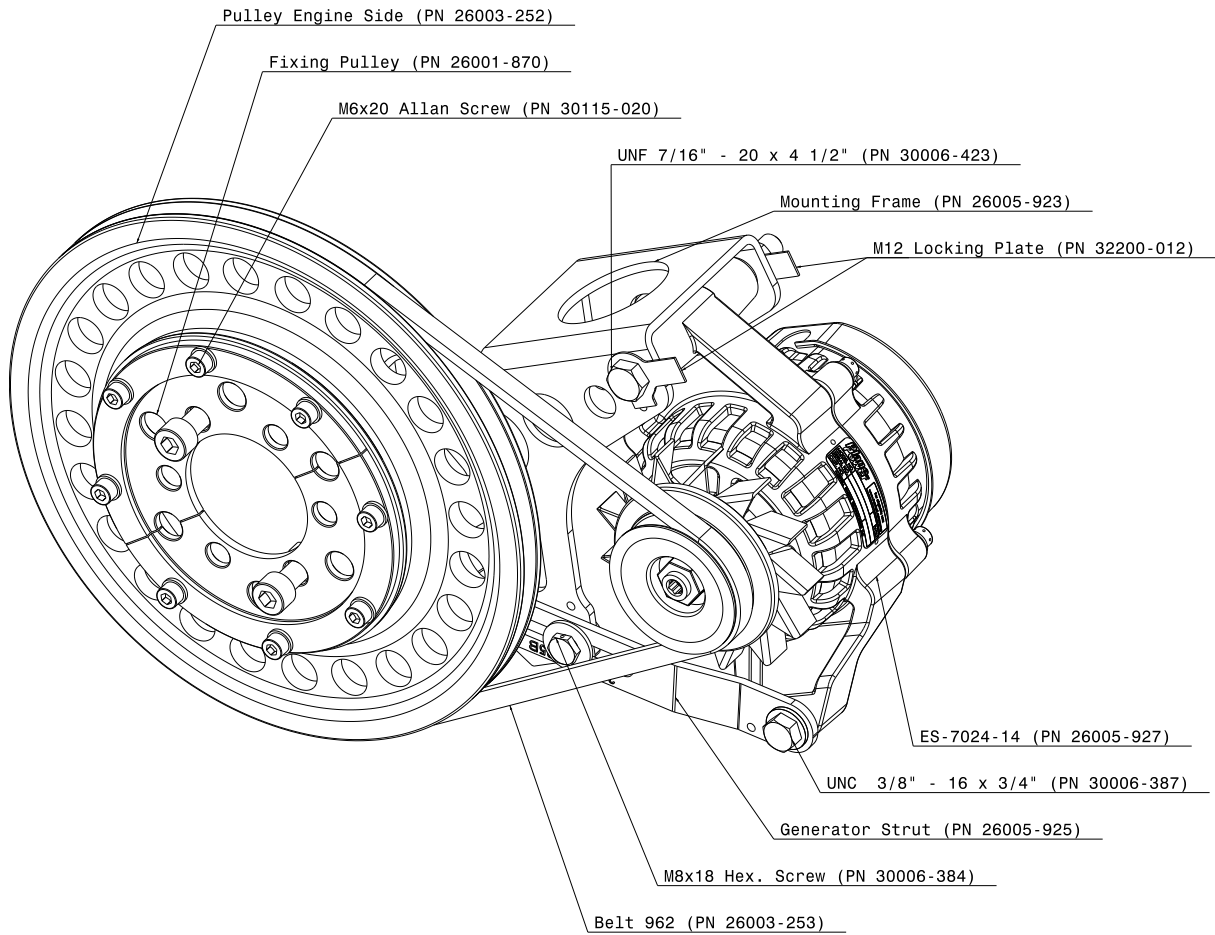

Figure 4-11 : Isometric view 70A 915iS

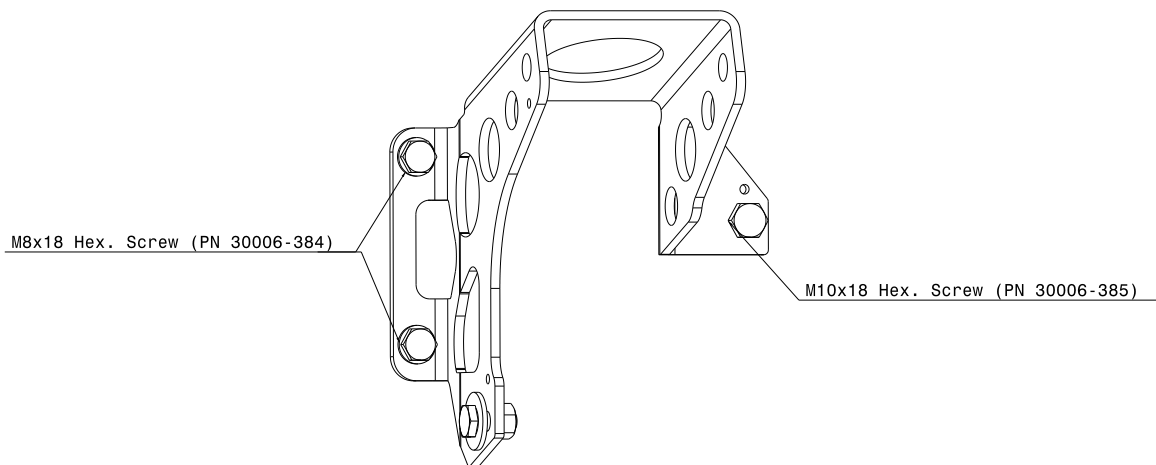

Figure 4-12 : Isometric view Mounting Frame 70A 915iS

4.7 Assembly Instructions 150A 915iS

1. Preassemble the **Side Frame LH** (PN 26001-871) with 2x **M8x18 Hexagon Screw** (PN 30006-384) and 2x **M8 Washer** (PN 32010-008) to the Rotax Attachment points L5 and L6. Do not tighten the screw yet.
2. Preassemble the **Side Frame RH** (PN 26001-872) with **M10x18 Hexagon Screw** (PN 30006-385) and **M10 Washer** (PN 32010-010) to the Rotax Attachment point L4. Do not tighten the screw yet.
3. Connect the **Side Frame LH** (PN 26001-871) and the **Side Frame RH** (PN 26001-872) with 2x **M8x20 Hexagon Screw** (PN 30006-022), 4x **M8 Washer** (PN 32010-008) and 2x **M8 Stop Nut** (PN 31500-007). Do not tighten the screws yet.
4. Insert the **Bracket** (PN 26001-873) and mount it with 4x **M5x16 Hexagon Screw** (PN 30004-103), 8x **M5 Washer** (PN 32010-005) and 4x **M5 Stop Nut** (PN 31500-005).
5. Tighten all screws from step 1-4. Safe the **M10x18 Hexagon Screw** (PN 30006-385) with safety wire against the **Side Frame RH** (PN 26001-872). Safe the 2x **M8x18 Hexagon Screw** (PN 30006-384) with safety wire against each other.
6. Place the **Pulley Engine Side** (PN 26003-252) behind the propeller flange. Mount the 2x **Fixing Pulley** (PN 26001-870) behind the propeller flange with 2x **M10x20 Socket Head Screw** (PN 30117-105). This mounting is temporary and will be replaced by the bolts of the propeller later.
7. Mount the **Pulley Engine Side** (PN 26003-252) on the 2x **Fixing Pulley** (PN 26001-870) with 8x **M6x20 Socket Head Screw** (PN 30115-020) and 8x **M6 Washer** (PN 32012-022). Apply Loctite 243 on all 8x **M6x20 Socket Head Screw** (PN 30115-020).
8. Apply battery terminal grease on all connections between the alternator and the bearings.
9. Place the Alternator in between the two mounting flanges of the Side Frame with the **UNF 7/16"-20 x6" Hexagon Screw** (PN 30006-422), **UNF 7/16"-20 Nut** (PN 44421-006) and two **M12 Locking Plates** (PN 32200-012). Adjust the position in x-direction with the **D12 Shim Ring** (PN 32062-006) and the **Distance Tube** (PN 26001-875) between the alternator and the Side Frames. The plane of the **Pulley Engine Side** (PN 26003-252) and the Pulley Generator Side must be equal. The assembly needs to fit tight between the Side Frame mounting flanges.
10. Mount the Belt (PN 26003-253) on both pulleys.
11. Mount the **Generator Strut** (PN 26001-876) on the **ALT-FLX** (PN 26001-862) with **UNC 3/8"-16 x 3/4"** (PN 20006-387) and **M10 Washer** (PN 32010-010). Do not tighten the screw yet.
12. Mount the **Generator Strut** (PN 26001-876) on the **Side Frame LH** (PN 26001-871) with **M8x18 Hexagon Screw** (PN 30006-384), **M8 Thick Washer** (PN 32051-009).
13. Mount the propeller as described in the propeller manual.
14. Move the alternator to tension the belt. The belt will soften at the first runs and needs to be retightened. Fix the position by tightening the screws on the **Generator Strut** (PN 26001-876). Secure the **UNC 3/8"-16 x 3/4"** (PN 20006-387) against the **Generator Strut** (PN 26001-876) with safety wire.

15. Tighten the **UNF 7/16"-20 x 6" Hexagon Screw** (PN 30006-422) and **UNF 7/16"-20 Nut** (PN 44421-006) and bend the edges of the **M12 Locking Plates** (PN 32200-012) according to usual procedure to secure them.
16. Torque all screws to specified values as seen in Table 4-1.
17. Thoroughly check the complete installation.

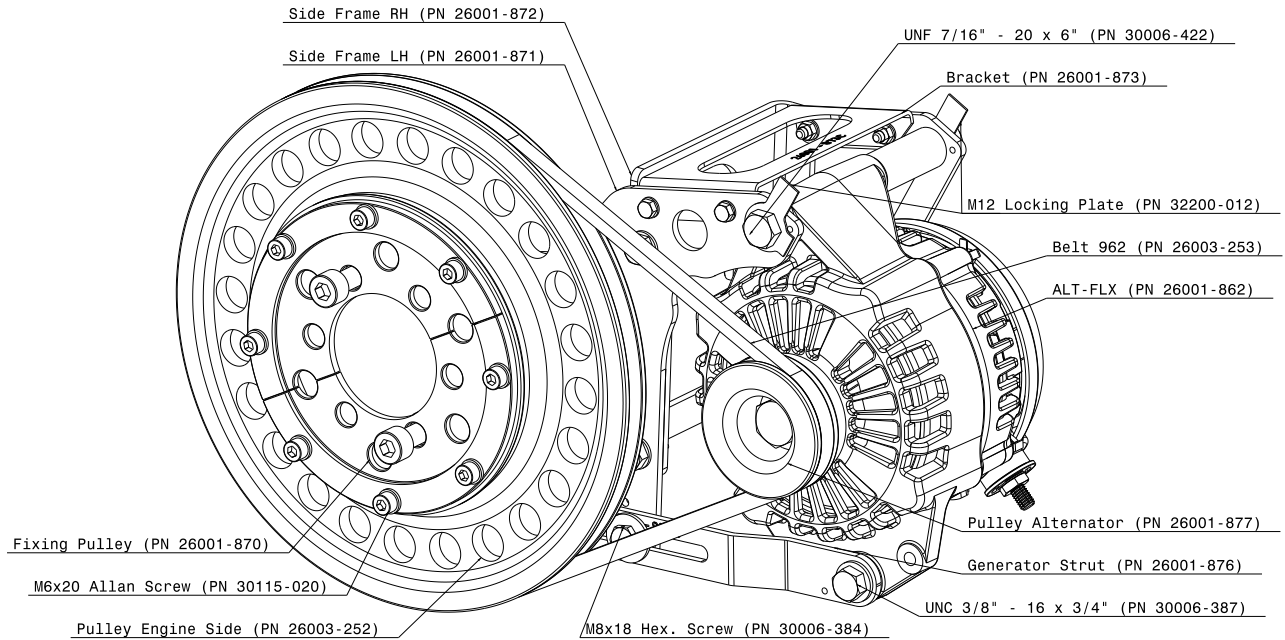

Figure 4-13 : Isometric view 150A 915iS

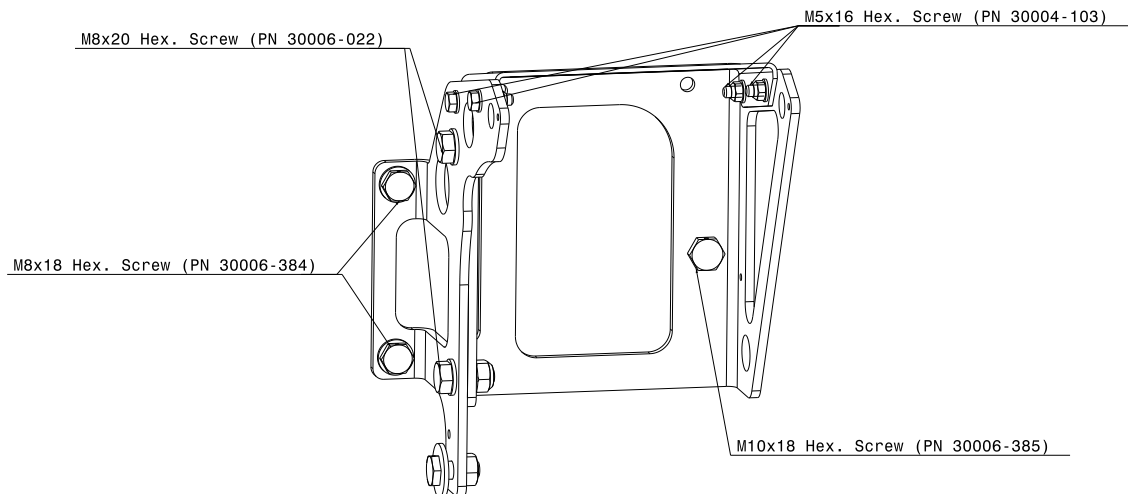

Figure 4-14 : Isometric view Side Frames 150A 915iS

4.8 Assembly Instructions 300A 912iS

1. Preassemble the **Side Frame LH** (PN 26007-315) with 2x **M8x18 Hexagon Screw** (PN 30006-384) and 2x **M8 Washer** (PN 32010-008) to the Rotax Attachment points L5 and L6. Do not tighten the screw yet.
2. Preassemble the **Side Frame RH** (PN 26007-316) with **M10x18 Hexagon Screw** (PN 30006-385) and **M10 Washer** (PN 32010-010) to the Rotax Attachment point L4. Do not tighten the screw yet.
3. Connect the **Side Frame LH** (PN 26007-315) and the **Side Frame RH** (PN 26001-872) with 3x **M8x20 Hexagon Screw** (PN 30006-022), 6x **M8 Washer** (PN 32010-008) and 3x **M8 Stop Nut** (PN 31500-007). Do not tighten the screws yet.
4. Insert the **Bracket** (PN 26007-317) and mount it with 4x **M5x16 Hexagon Screw** (PN 30004-103), 8x **M5 Washer** (PN 32010-005) and 4x **M5 Stop Nut** (PN 31500-005).
5. Preassemble the **Side Frame LH** (PN 26001-872) with 2x **M8x18 Hexagon Screw** (PN 30006-384) and 2x **M8 Washer** (PN 32010-008) to the Rotax Attachment points L5 and L6. Do not tighten the screw yet.
6. Preassemble the **Side Frame RH** (26007-322) with **M10x18 Hexagon Screw** (PN 30006-385) and **M10 Washer** (PN 32010-010) to the Rotax Attachment point L4. Do not tighten the screw yet.
7. Insert the **Bracket** (PN 26001-873) and mount it with 4x **M5x16 Hexagon Screw** (PN 30004-103), 8x **M5 Washer** (PN 32010-005) and 4x **M5 Stop Nut** (PN 31500-005).
8. Insert the **Connecting Bracket** (PN 26007-319) and mount it with 4x **M6x20 Hexagon Screw** (PN 30005-020), 8x **M6 Washer** (PN 32010-006) and 4x **M6 Stop Nut** (PN 31500-006).
9. Tighten all screws from step 1-8. Safe the **M10x18 Hexagon Screw** (PN 30006-385) with safety wire against the **Side Frame RH** (PN 26001-872). Safe the 2x **M8x18 Hexagon Screw** (PN 30006-384) with safety wire against each other.
10. Place the **Pulley Engine Side** (PN 26007-312) behind the propeller flange. Mount the 2x **Fixing Pulley** (PN 26001-870) behind the propeller flange with 2x **M10x20 Socket Head Screw** (PN 30117-105). This mounting is temporary and will be replaced by the bolts of the propeller later.
11. Mount the **Pulley Engine Side** (PN 26007-312) on the 2x **Fixing Pulley** (PN 26001-870) with 8x **M6x20 Socket Head Screw** (PN 30115-020) and 8x **M6 Washer** (PN 32012-022). Apply Loctite 243 on all 8x **M6x20 Socket Head Screw** (PN 30115-020).
12. Apply battery terminal grease on all connections between the alternator and the bearings.
13. Place one Alternator in between the two mounting flanges of the Side Frames on the aircrafts left hand side in DOF with the **UNF 7/16"-20 x6" Hexagon Screw** (PN 30006-422), **UNF 7/16"-20 Nut** (PN 44421-006) and two **M12 Locking Plates** (PN 32200-012). Adjust the position in x-direction with the **D12 Shim Ring** (PN 32062-006) and the **Distance Tube** (PN 26001-875) between the alternator and the Side Frames. The plane of the **Pulley Engine Side** (PN 26007-312) and the Pulley Generator Side must be equal. The assembly needs to fit tight between the Side Frame mounting flanges.
14. Place the other Alternator in between the two mounting flanges of the Side Frames on the aircrafts right hand side in DOF with the **UNF 7/16"-20 x6" Hexagon Screw** (PN 30006-422),

UNF 7/16"-20 Nut (PN 44421-006) and two **M12 Locking Plates** (PN 32200-012). Adjust the position in x-direction with the **D12 Shim Ring** (PN 32062-006) and the **Distance Tube** (PN 26001-875) between the alternator and the Side Frames. The plane of the **Pulley Engine Side** (PN 26007-312) and the Pulley Generator Side must be equal. The assembly needs to fit tight between the Side Frame mounting flanges.

15. Mount both Belts (PN 26003-253) on both Alternator pulleys and the **Pulley Engine Side** (PN 26007-312).
16. Mount the propeller as described in the propeller manual.
17. Move the alternator to tension the belt and fasten with **UNC 3/8"-16 x 3/4"** (PN 20006-387) and a **Thick Washer M10** (PN 32010-010). The belt will soften at the first runs and needs to be retightened. Secure the **UNC 3/8"-16 x 3/4"** (PN 20006-387) on both sides with safety wire to the nearest Side Frame.
18. Tighten the **UNF 7/16"-20 x6" Hexagon Screw** (PN 30006-422) and **UNF 7/16"-20 Nut** (PN 44421-006) on both sides and bend the edges of the **M12 Locking Plates** (PN 32200-012) according to usual procedure to secure them.
19. Torque all screws to specified values as seen in Table 4-1.
20. Thoroughly check the complete installation.

4.9 Additional Drawings and Tables

Screw Type	Torque
All M6 screws into aluminum	5.9 Nm / 4.3 lbft
All M6 screws into a nut	9.6 Nm / 7.0 lbft
All M8 screws into aluminum	14.3 Nm / 10.5 lbft
All M8 screws into a nut	23.0 Nm / 19.9 lbft
All M10 screws into aluminum	28.3 Nm / 20.8 lbft
Upper screws in gearbox	10.0 Nm / 7.3 lbft
All UNC 3/8" screws	36.0 Nm / 27.0 lbft
All UNF 7/16" screws	65.0 Nm / 48.0 lbft

Table 4-1: Torque Specifications

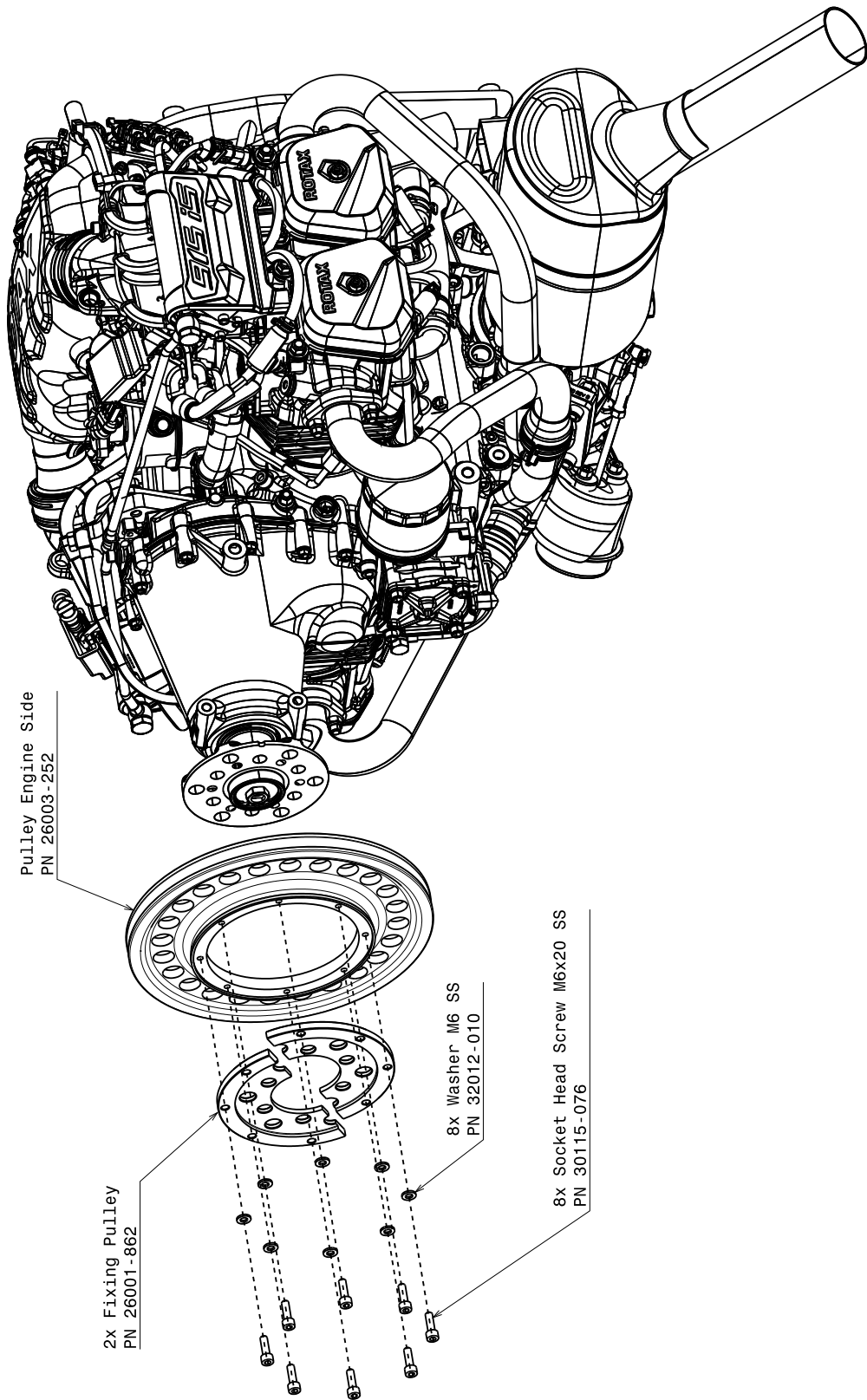
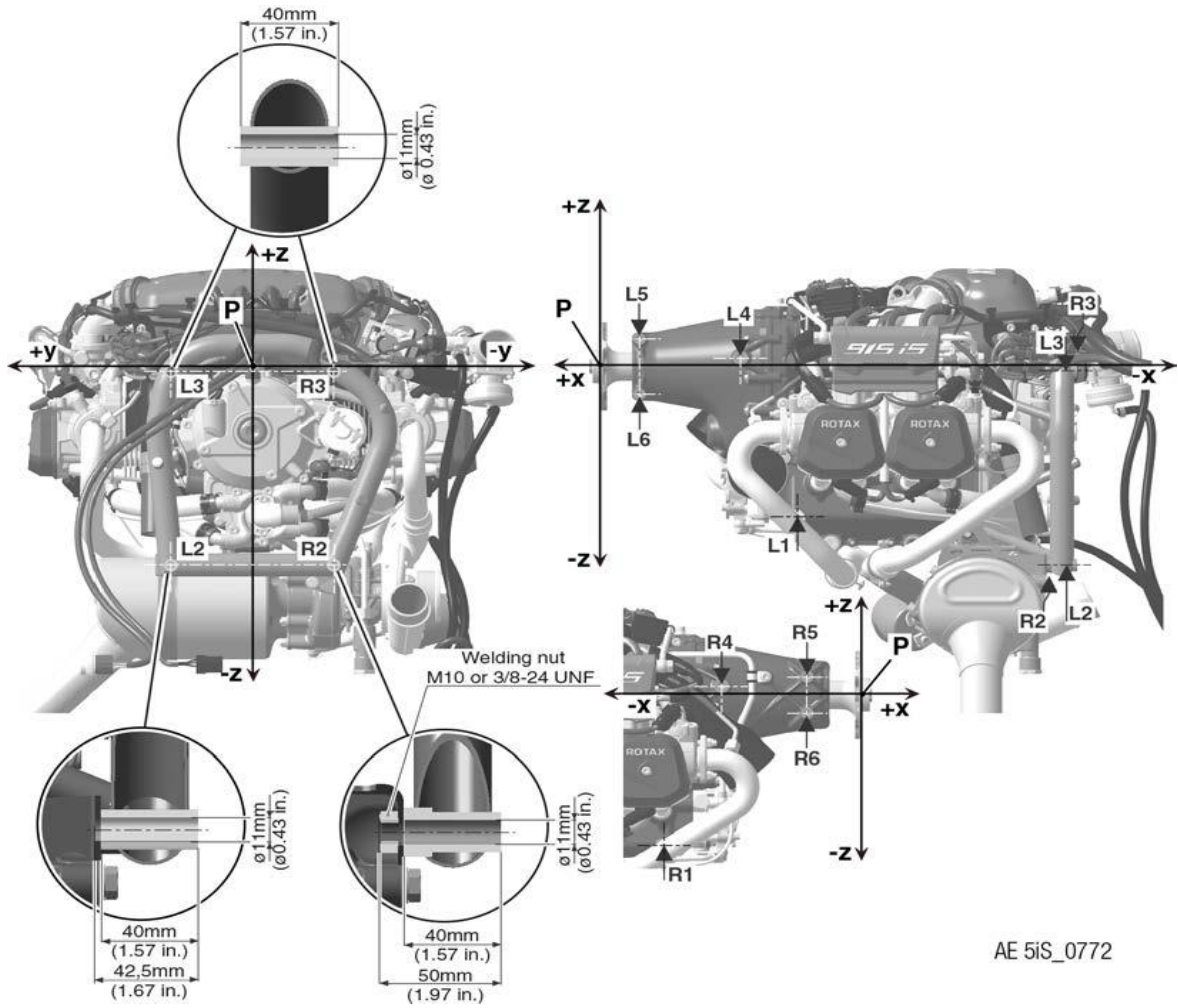

Figure 4-15: Installation of the Pulley Engine Side for all 70A and 150A Assemblies

Note: The Fixing Pulleys (PN 26001-862) are mounted behind the propeller flange (view DOF). The Pulley is mounted behind the Fixing Pulleys (view DOF).



AE 5iS_0772

Figure 4-16: 915iS Attachment points

5. Electrical Installation and Operation

5.1 Electrical Installation for all 150A Alternators

The 150A Alternator has to be installed with a R1224 Regulator as seen in Figure 5-3.

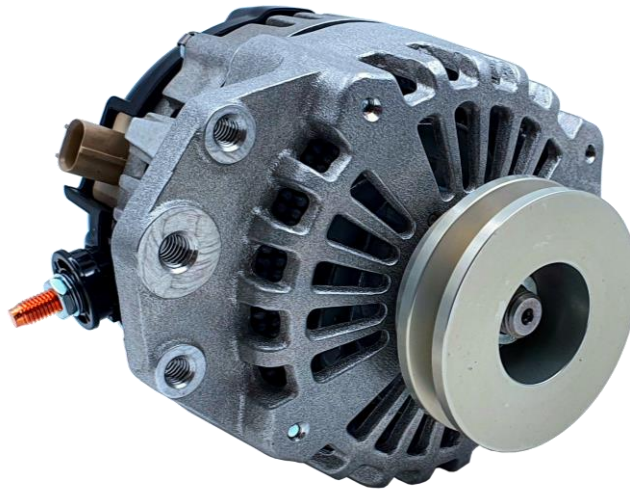

Figure 5-1 : 150A Alternator

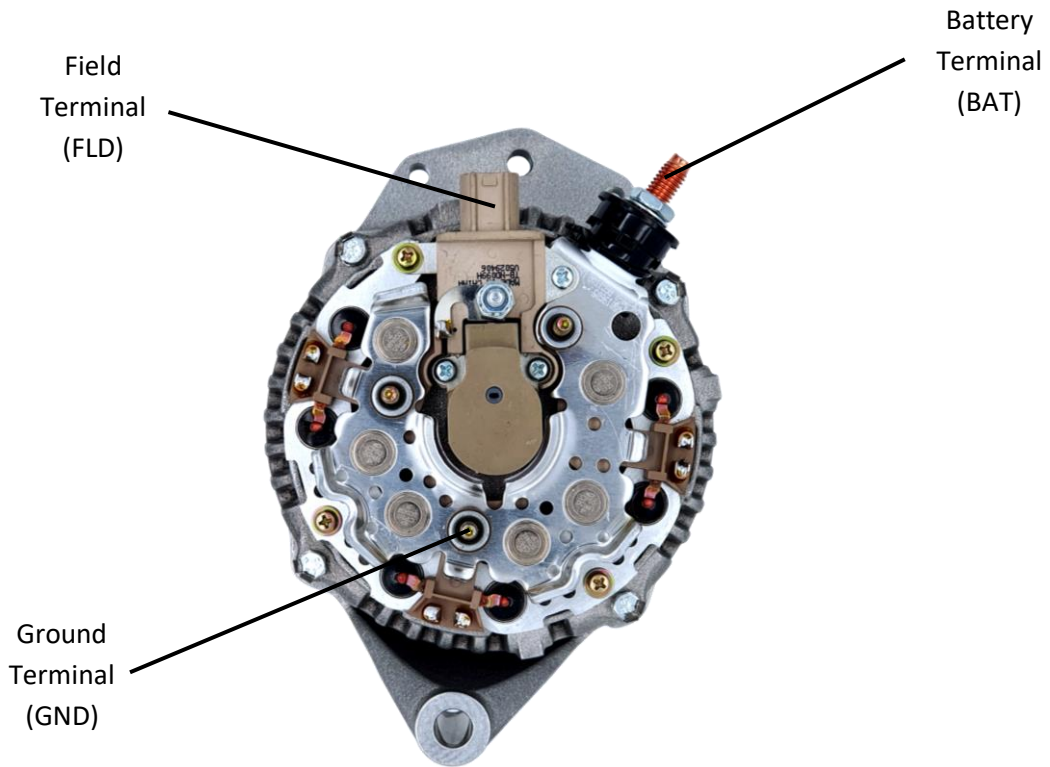

Figure 5-2 : Electrical connection points 150A Alternator

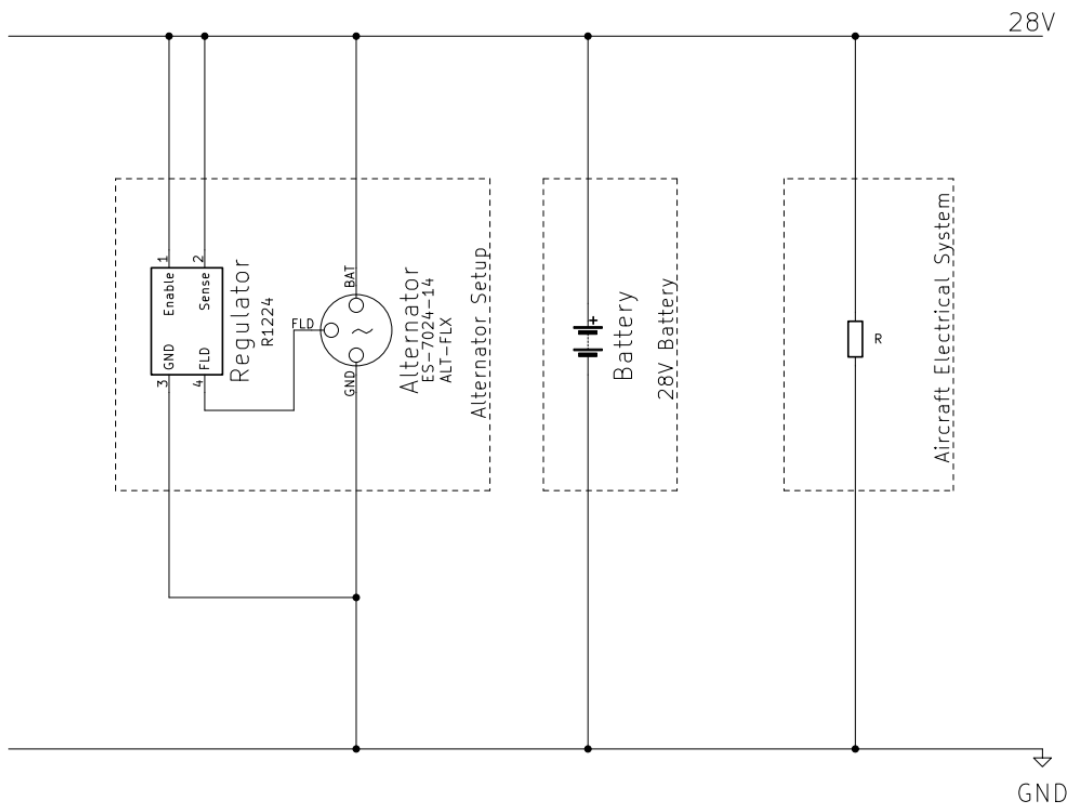

Figure 5-3 : Wiring Diagram 150A Alternator

5.2 Electrical Installation for all 70A Alternators

The 70A Alternator has to be installed with a R1224 Regulator as seen in Figure 5-6.



Figure 5-4 : 70A Alternator

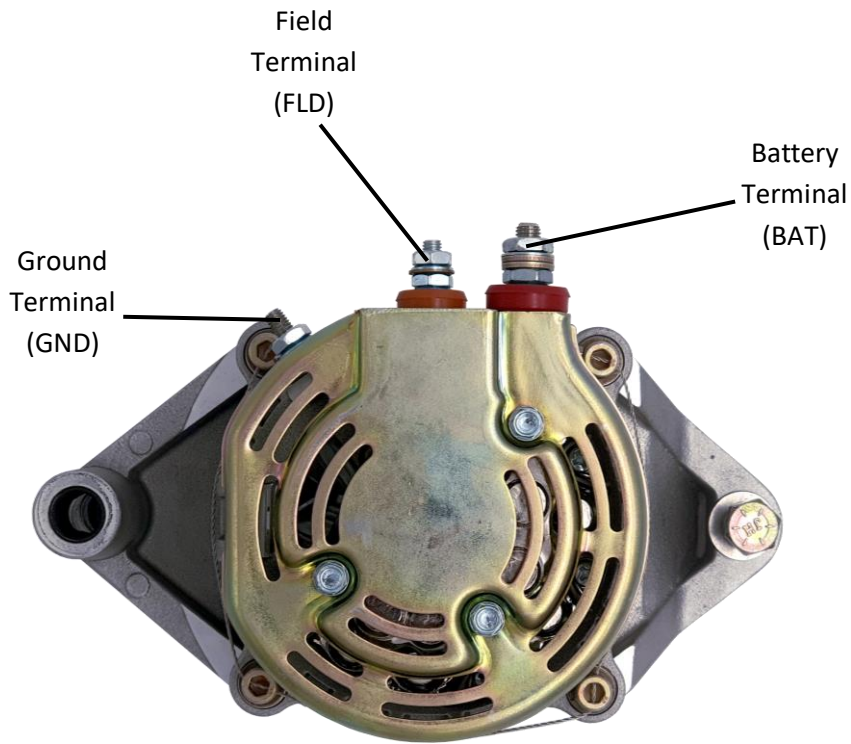

Figure 5-5 : Electrical connection points 70A Alternator

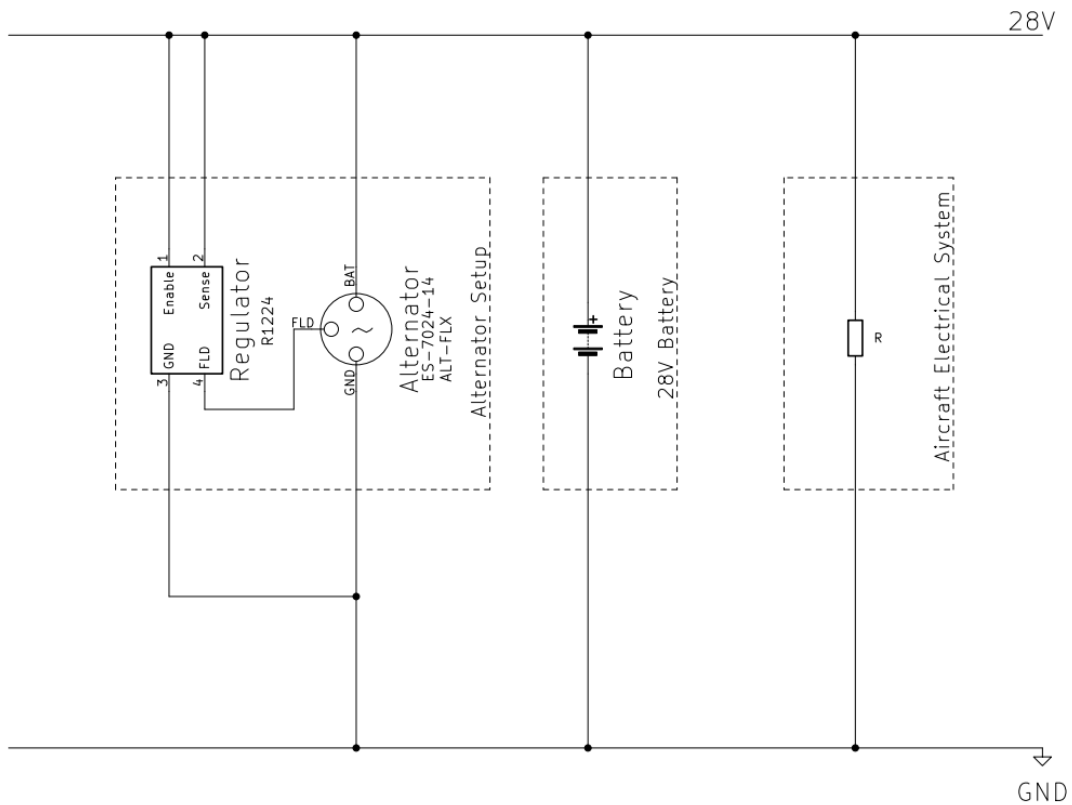

Figure 5-6 : Wiring Diagram 70A Alternator

5.3 Electrical Installation for all 20A Alternators

The 20A Alternator is internally regulated. A possible wiring setup can be seen in Figure 5-7.

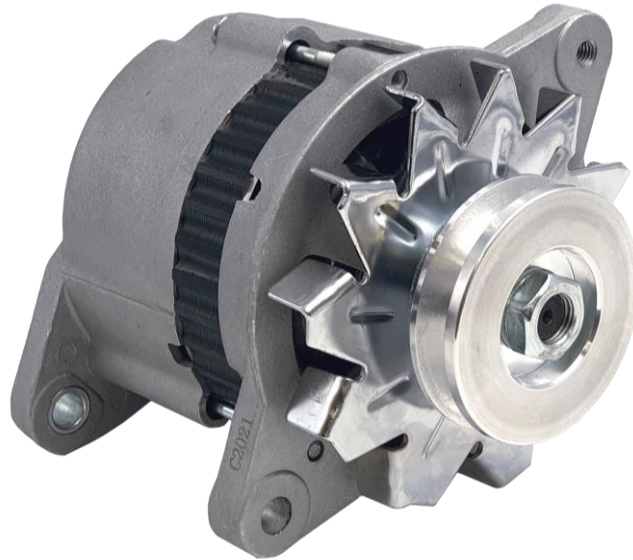

Figure 5-3-1: 20A Alternator

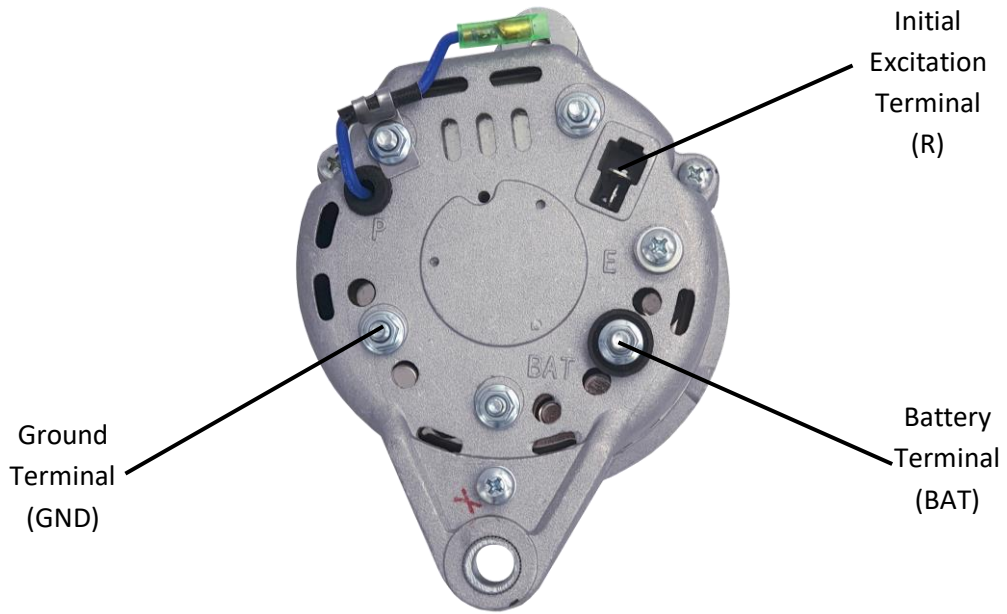

Figure 5-3-2: Electrical connection points 20A Alternator

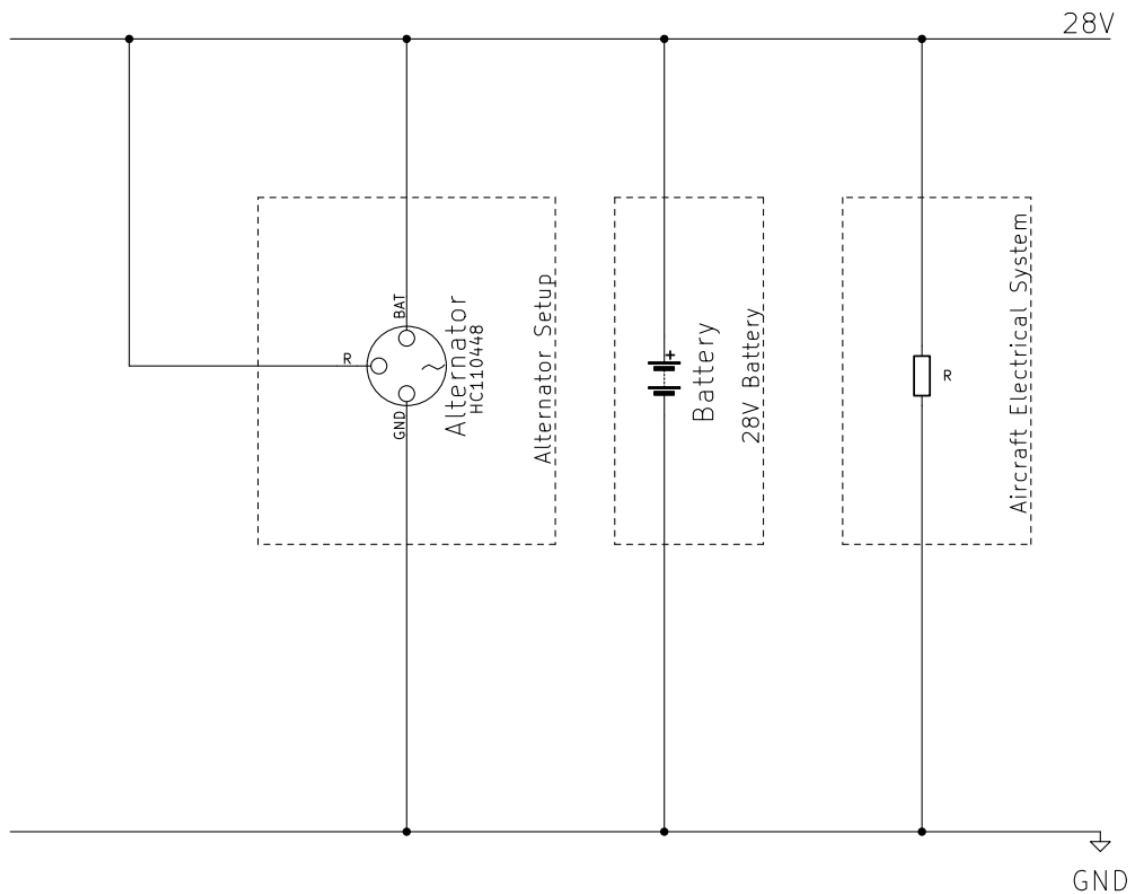

Figure 5-7 : Wiring Diagram 20A Alternator

5.4 R1224 Regulator Installation

Mechanical dimensions: 120 mm x 70 mm x 24 mm

Weight: 257 g

For more Information about the R1224 see Plane Power Document – R122a Regulator Installation Instructions.

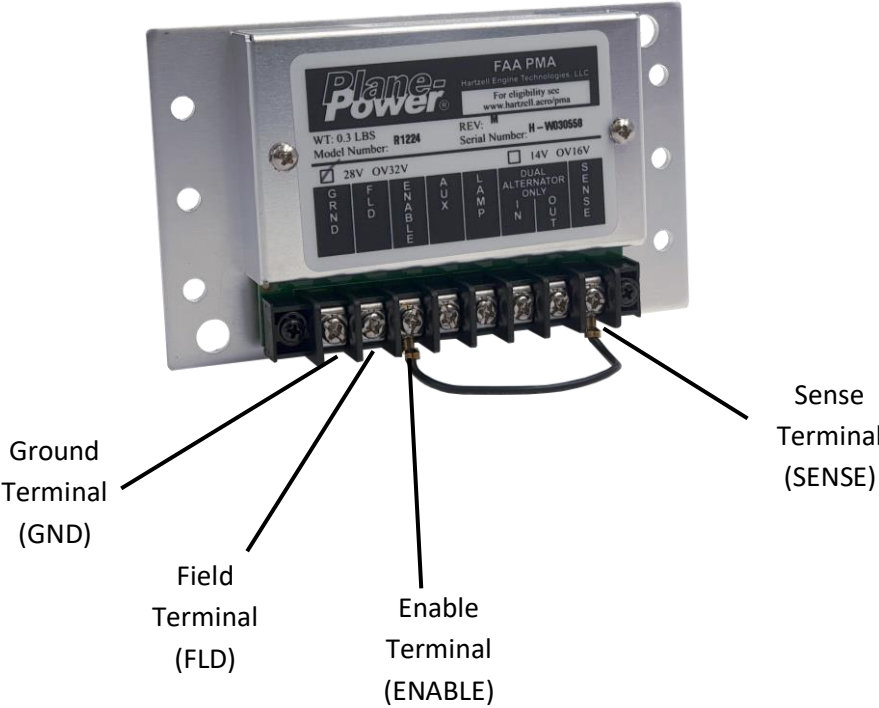

6. Performance Charts

6.1 Performance Chart 20A 912iS

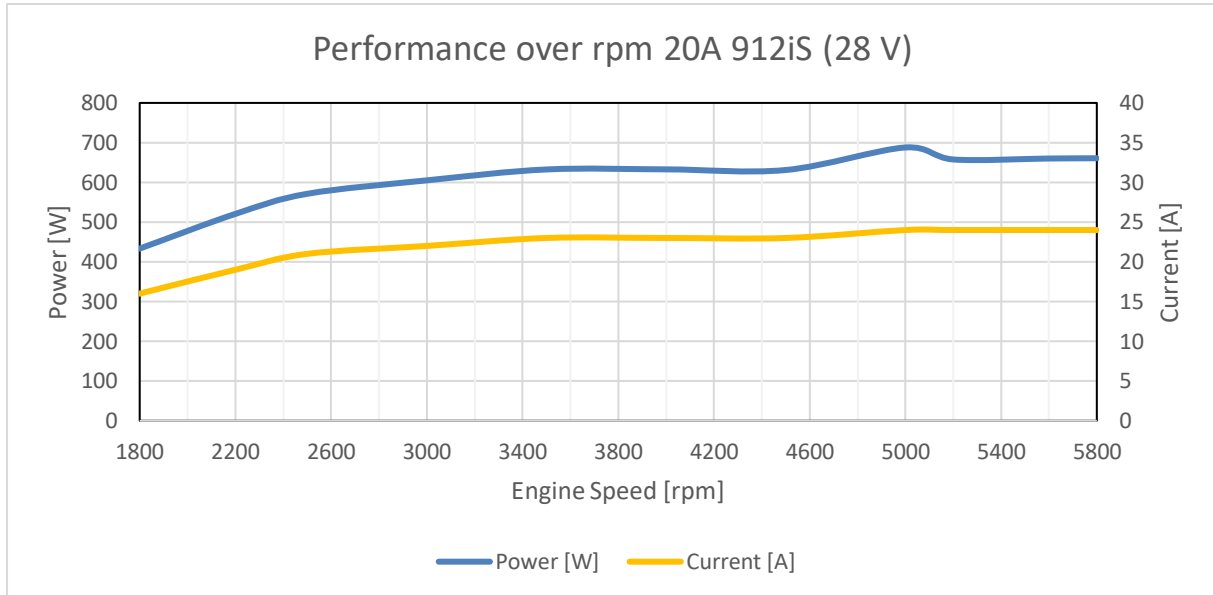

Figure 6-1 : Performance over rpm 20A 912iS

6.2 Performance Chart 70A 912iS

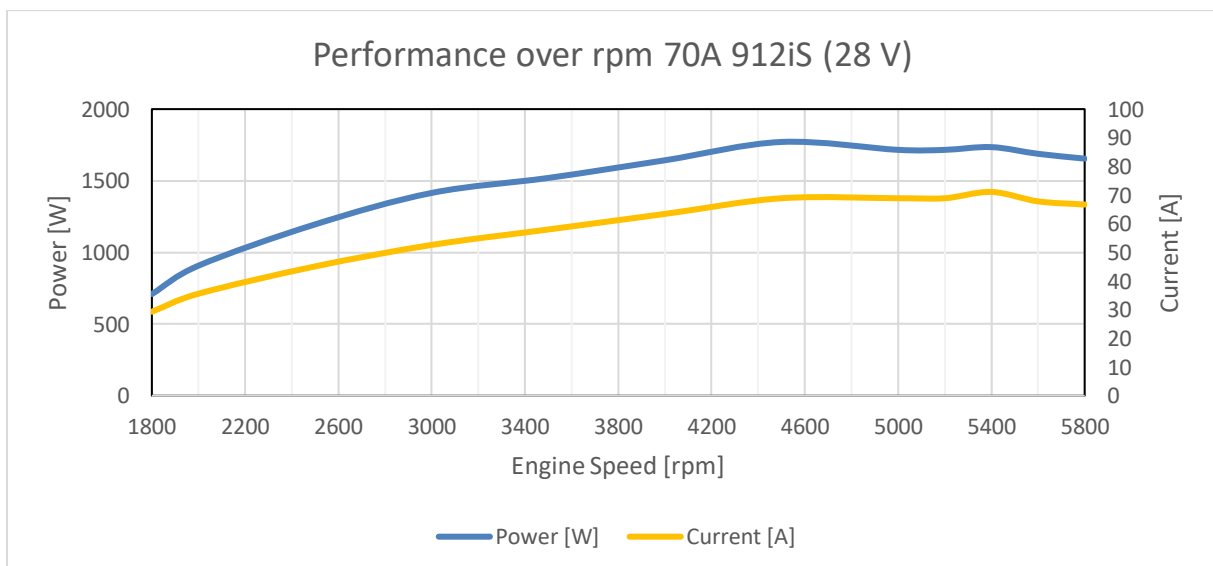

Figure 6-2 : Performance over rpm 70A 912iS

6.3 Performance Chart 150A 912iS

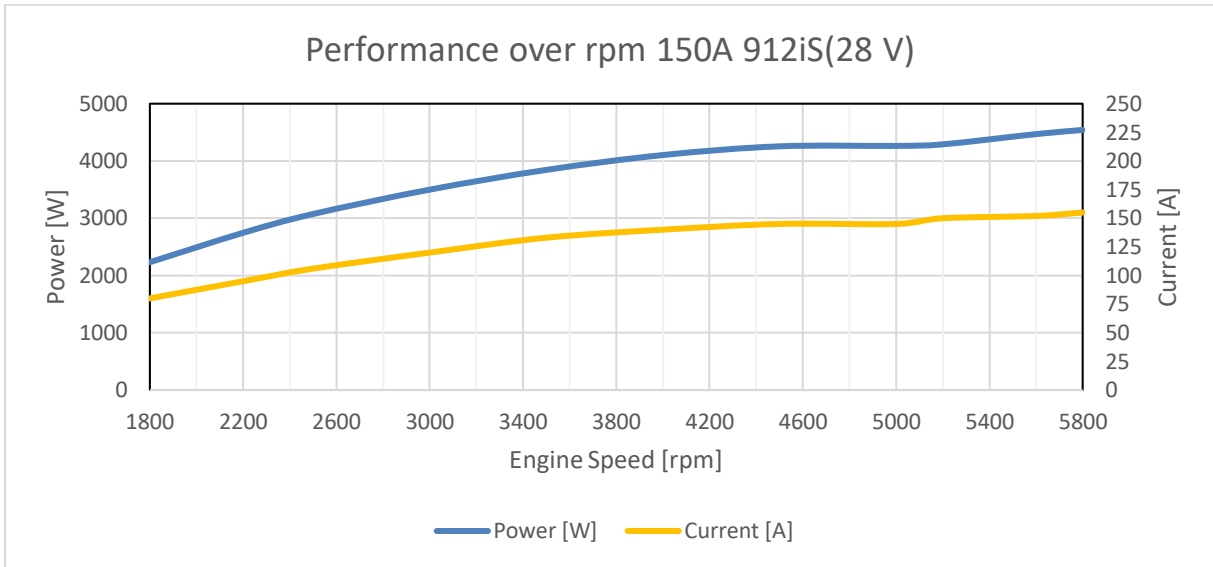

Figure 6-3 : Performance over rpm 150A 912iS

6.4 Performance Chart 20A 915iS

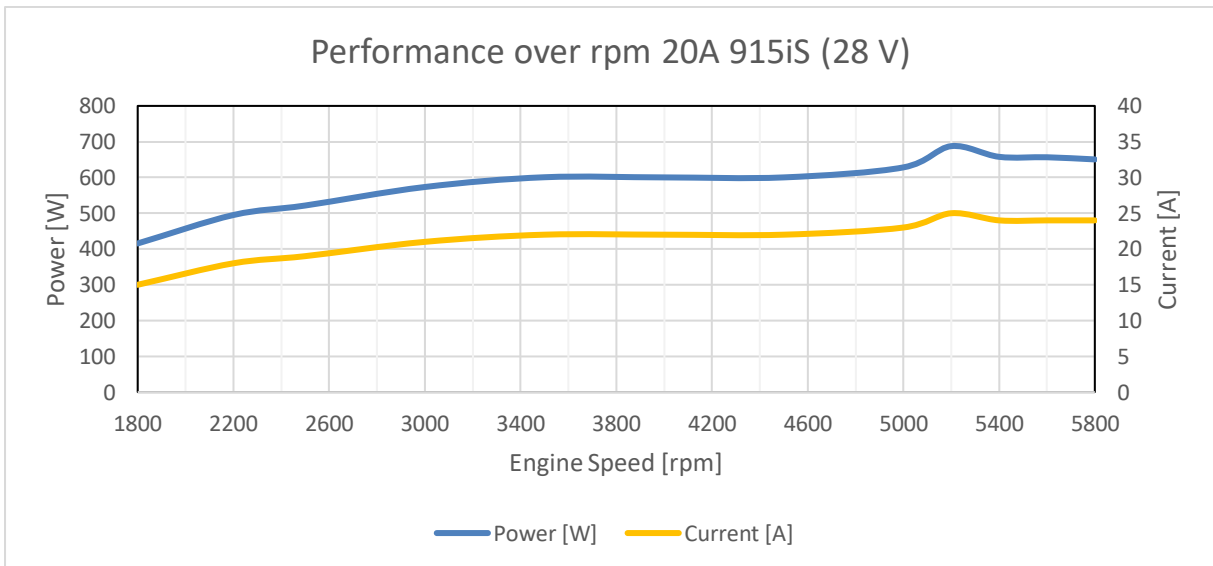

Figure 6-4 : Performance over rpm 20A 915iS

6.5 Performance Chart 70A 915iS

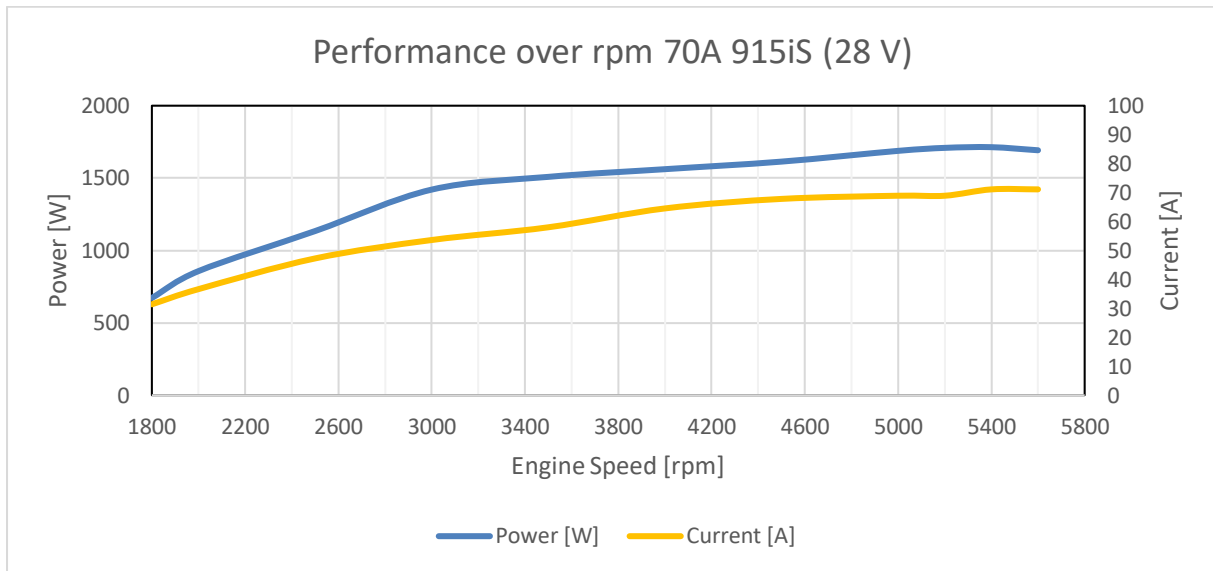

Figure 6-5 : Performance over rpm 70A 915iS

6.6 Performance Chart 150A 915iS

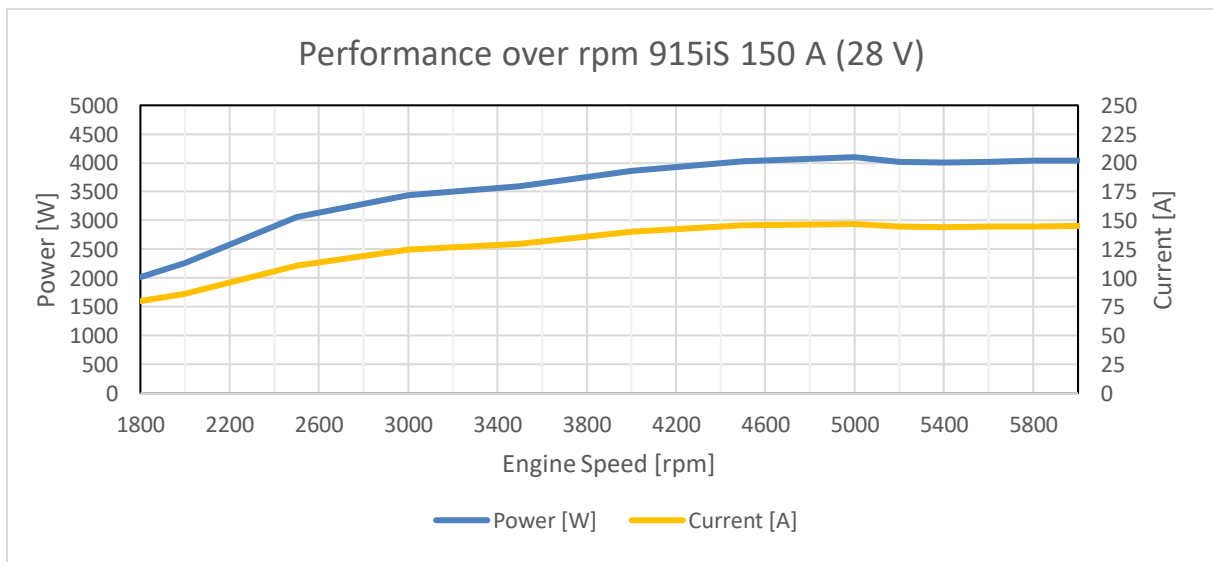

Figure 6-6 : Performance over rpm 150A 915iS

6.7 Performance Chart 300A 915iS

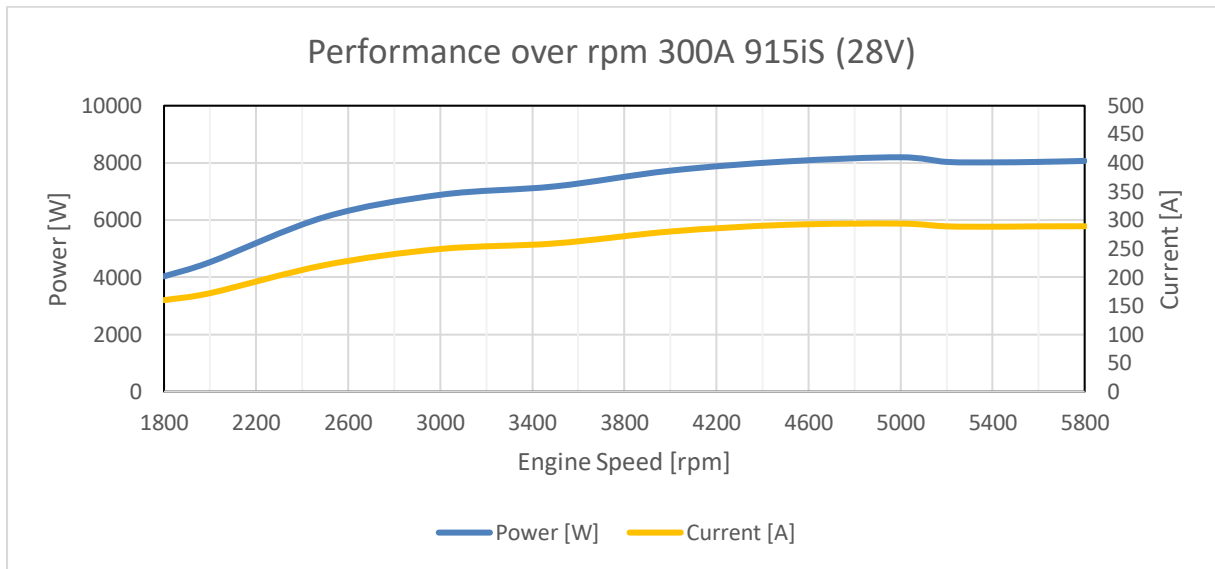

Figure 6-7 : Performance over rpm 300A 915iS

End of Document.



RS Flight Systems GmbH

Oberer Luessbach 29-31

82335 Berg | Germany

+49 8178 8681 – 300

contact@rs-flightsystems.com

www.rs-flightsystems.com

External Alternator Series for BRP Rotax Aircraft Engines | Issue 1.0

© Copyright 2022 RS Flight Systems GmbH