

# Installation / Operation Manual

iS Engine Panel V3



Contents

- 1. Preface .....3
- 2. System Description .....3
- 3. Technical Specifications .....5
- 4. Electrical Installation ..... 10
  - 4.1 Electrical Installation in combination with EMU/SCU ..... 10
  - 4.2 Electrical Installation standalone..... 13
- 5. Operation..... 16
  - 5.1 Operation with EMU (Variant 1)..... 16
  - 5.2 Operation standalone (Variant 2)..... 17

# 1. Preface

Thank you for purchasing an RS Flight Systems iS Engine Panel V3. We are pleased that you have chosen our product and are confident that it will meet all your expectations. In case of questions or problems with the unit, feel free to contact us:

**RS Flight Systems GmbH**  
**Oberer Luessbach 29-31**  
**82335 Berg | Germany**  
**Phone: +49-8178-8681-300**  
**E-Mail: [contact@rs-flightsystems.com](mailto:contact@rs-flightsystems.com)**

# 2. System Description

The iS Engine Panel V3 is an optional extension unit specifically developed for BRP Rotax iS engines. Its main functions is to provide all necessary switches for Rotax iS engine operation.

The switching characteristics of the iS Engine Panel V3 differ from the ones for the Rotax 912 and 914 engine series. Therefore, the different engine series have an altered starting procedure. For the starting procedure, see chapter 5. Operation. The iS Engine Panel V3 includes the control of LANE A and LANE B as well as the Main Fuel Pump and the Auxiliary Fuel Pump via a turning switch. The iS Engine Panel V3 is shown in Figure 2-2.

The scope of delivery consists of:

- 1x Preassembled iS Engine Panel V3
- 2x Start Key
- 2x Ring Cable Lug 0.5-1.0mm<sup>2</sup> M3
- 4x Ring Cable Lug 1.1-2.5mm<sup>2</sup> M3
- 16x Ring Cable Lug 0.5-1.1mm<sup>2</sup> M4
- 10x Ring Cable Lug 1.1-2.5mm<sup>2</sup> M4



Figure 2-1: iS Engine Panel V3 front view



Figure 2-2: iS Engine Panel V3 isometric view

### 3. Technical Specifications

The technical specifications of the iS Engine Panel V3 are listed in Table 3-1. The dimensions of the panel cut-out can be seen in Figure 3-1.

	iS Engine Panel V3
Mechanical Dimensions (width, height, depth)	146 x 66 x 131 mm 5.75 x 2.6 x 5.16 in
Panel Cutout Dimensions (width, height)	138 x 58 mm, 12mm corner radius 5.42 x 2.28 in, 0.47in corner radius
Mounting Depth excl. Connectors	92 mm 3.62 in
Maximum Panel Thickness	6 mm 0.23 in
Mounting	4 x M4 Screws
Total Mass	0.460 kg 1.01 lbs
Operating Altitude	< 7,620 m < 25,000 ft
Operating Temperature Range	-20 to +70 °C -4 to +158 °F
Humidity	< 95 %, non-condensing

**Table 3-1: Technical specification**

The mechanical dimensions are shown in the technical drawings in Figure 3-1 , Figure 3-2, Figure 3-3, and Figure 3-4.

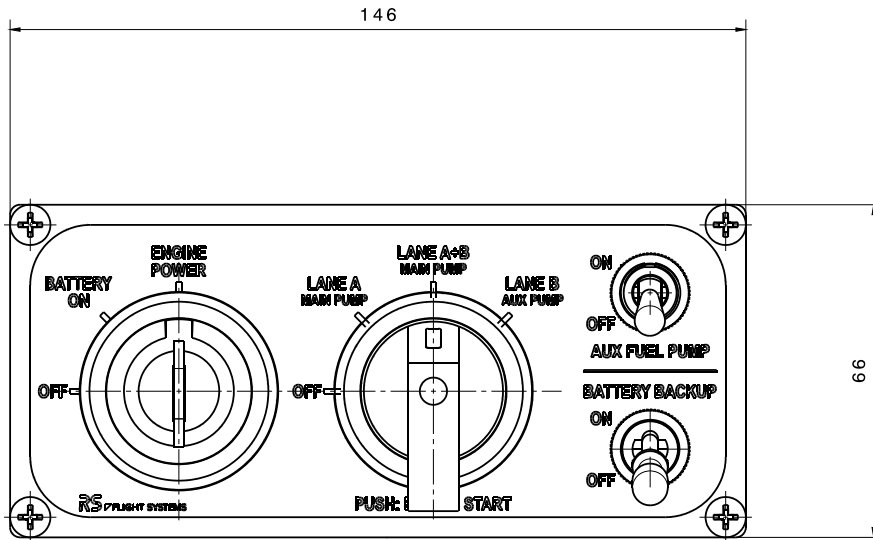

Figure 3-1: iS Engine Panel V3 drawing front view

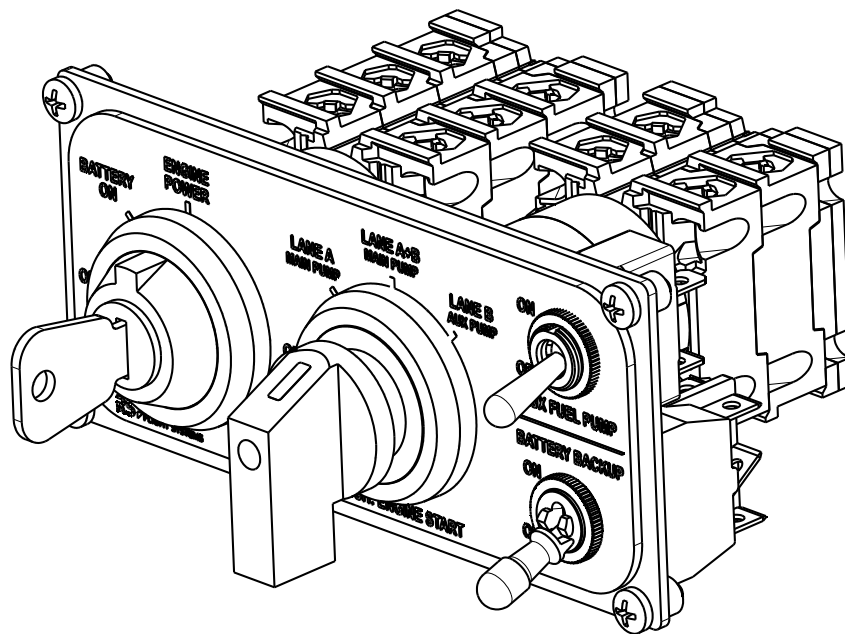
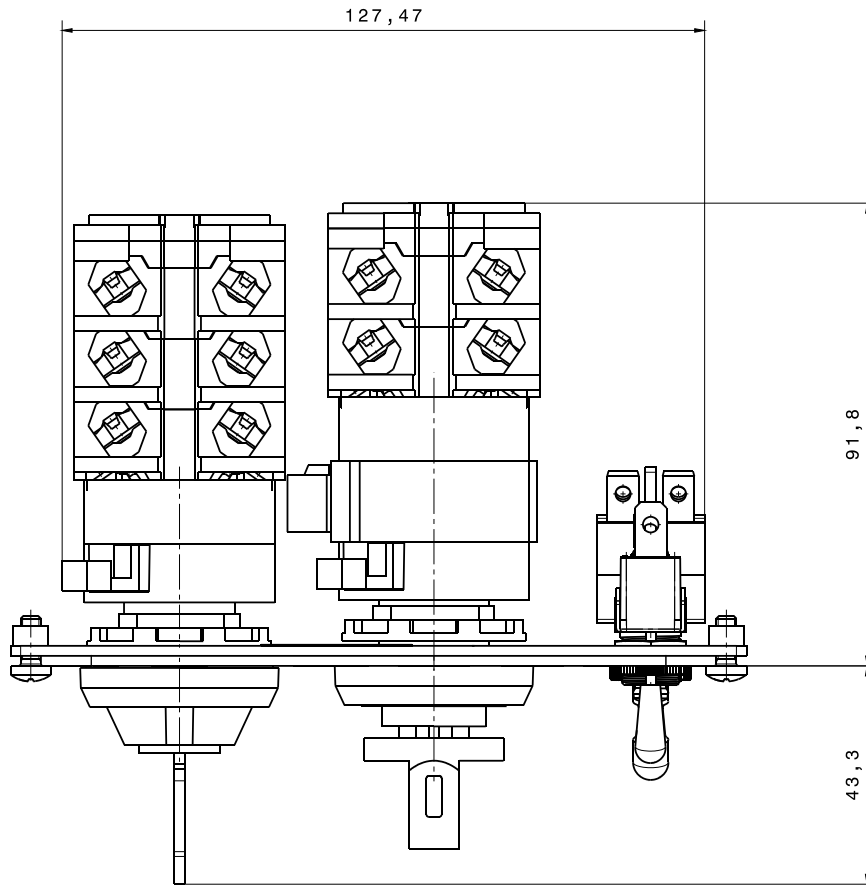
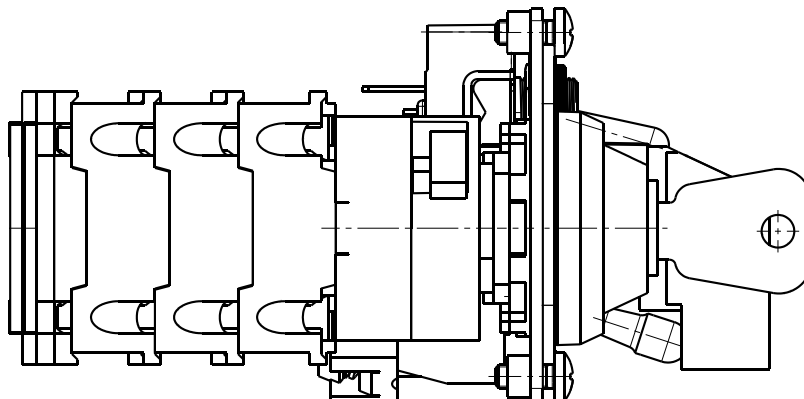

Figure 3-2: iS Engine Panel V3 drawing isometric view



**Figure 3-3: iS Engine Panel V3 drawing top view**



**Figure 3-4: iS Engine Panel V3 drawing side view**

The switching logic is listed in Table 3-2 and Table 3-3 . “On” means the corresponding pin numbers are electrically conductive. “-” means the corresponding pin numbers are electrically non-conductive.

	Name	BAT ON	SCU / EMU ON	LANE A	LANE B	Backup BAT	GND
Name	Position Pin	1/2	3/4	5/6	7/8	9/10	11/12
OFF	0°	-	-	-	-	-	On
BATTERY ON	45°	On	-	-	-	On	-
ENGINE POWER	90°	On	On	On	On	On	-

**Table 3-2: Start Switch Key switching arrangement**

Description of the Positions of the Start Switch Key:

BAT ON	Activation of the relay of the avionic bus (Avionic Master Switch)
SCU / EMU ON	Activation of the SCU / EMU (which activates the Start Power Relay)
LANE A/B	Optional. Note: No deactivation of the of the Avionic Master without deactivation of the Lanes. If not used, engine can be started w/o key.
Backup BAT	Optional. Note: Avoids unintended activation of the Backup Battery Switch. Note: No engine restart with Avionic Master off possible.
GND	Short-cuts EMS ground (A) and Aircraft ground (B) for common ground for refueling.



	Name	LANE A	LANE B	Fuel Pump Main	Fuel Pump AUX	Starter
Name	Position Pin	1/2	3/4	5/6	7/8	13/14
OFF	0°	-	-	-	-	-
LANE A + FP Main	45°	On	-	On	-	-
Lane A+B + FP Main	90°	On	On	On	-	-
PUSH	90°	On	On	On	-	On
Lane B + FP Aux	135°	-	On	-	On	-

**Table 3-3: Lane Switch Knob switching arrangement**

Description of the Positions of the Lane Switch Knob:

LANE A	Activation of Lane A (optional routing via Start Switch Key)
LANE B	Activation of Lane B (optional routing via Start Switch Key)
Fuel Pump Main	Activation of main fuel pump (pump A)
Fuel pump Aux	Activation of auxiliary fuel pump (pump B)
Starter	Activation of the engine starter

Note: The start power function (supplying power from the aircraft battery to the EMS) is not covered by the iS Engine Panel V3. The switching logic is implemented in the SCU 9iS or in the EMU 9xiS Engine Management Unit. If no SCU9iS or EMU9xiS is installed, a separate momentary toggle switch must be used for the activation of the start power or the wiring variant “standalone” must be used.

## 4. Electrical Installation

The switches of the iS Engine Panel V3 are connected to the Rotax HIC connectors A and B. The detailed pinout is listed in Table 4-1 and Table 4-2 and shown in the sketch in Figure 4-1.

### 4.1 Electrical Installation in combination with EMU/SCU

Pin Engine Switch	Connector	Pin	Signal Name	Signal Description	Current / Wire Size
1	-	-	BAT	BAT Supply	
2	-	-	BAT	BAT Signal	
3	-	-	SCU	SCU / EMU Supply	AWG 22
4	-	-	SCU	SCU / EMU Signal	AWG 22
5	HIC A	1	LANE_SEL_SW_A_1	Lane A Supply	7.5 A
6	Lane Switch	2	LANE_SEL_SW	Lane A Signal	7.5 A
7	HIC B	1	LANE_SEL_SW_B_1	Lane B Supply	7.5 A
8	Lane Switch	4	LANE_SEL_SW	Lane B Signal	7.5 A
9	-	-	BAT_BCKP	BATTERY BACKUP Supply	
10	-	-	BAT_BCKP	BATTERY BACKUP Signal	
11	-	-	GND	EMS GND	AWG 22
12	-	-	GND	Aircraft GND	AWG 22

**Table 4-1: Engine Switch (Key) pinout**

Pin Lane Switch	Connector	Pin	Signal Name	Signal Description	Current / Wire Size
1	HIC A	7	LANE_SEL_SW_A_2	Lane A Supply	7.5 A
2	Start Key Switch	6	LANE_SEL_SW	Lane A Signal	7.5 A
3	HIC B	9	LANE_SEL_SW_B_2	Lane B Supply	7.5 A
4	Start Key Switch	8	LANE_SEL_SW	Lane B Signal	7.5 A
5	HIC A	3	SIG_FUEL_PUMP_1	Fuel Pump Main Signal	10 A
6	HIC A	9	GND_FUEL_PUMP_1	Fuel Pump Main Supply	10 A
7	HIC B	11	GND_FUEL_PUMP_2	Fuel Pump AUX Supply	10 A
8	HIC B	3	SIG_FUEL_PUMP_2	Fuel Pump AUX Signal	10 A
013	HIC B	4	CONN_STARTER_REL_SW	Starter Signal	5 A
014	HIC B	12	SUPP_START_SWITCH	Starter Supply	5 A

**Table 4-2: Lane Switch (Knob) pinout**

The auxiliary fuel pump switch must be wired in parallel to Pin 7 and 8 of the Lane Switch

The “Battery Backup” Switch can be used to control a relay (backup battery relay) or with direct wiring to the battery and the EMS / AC ground. The backup power supply can be routed optional through Pin 9-10 of the Engine Switch. In this case, a separate main power switch is necessary.

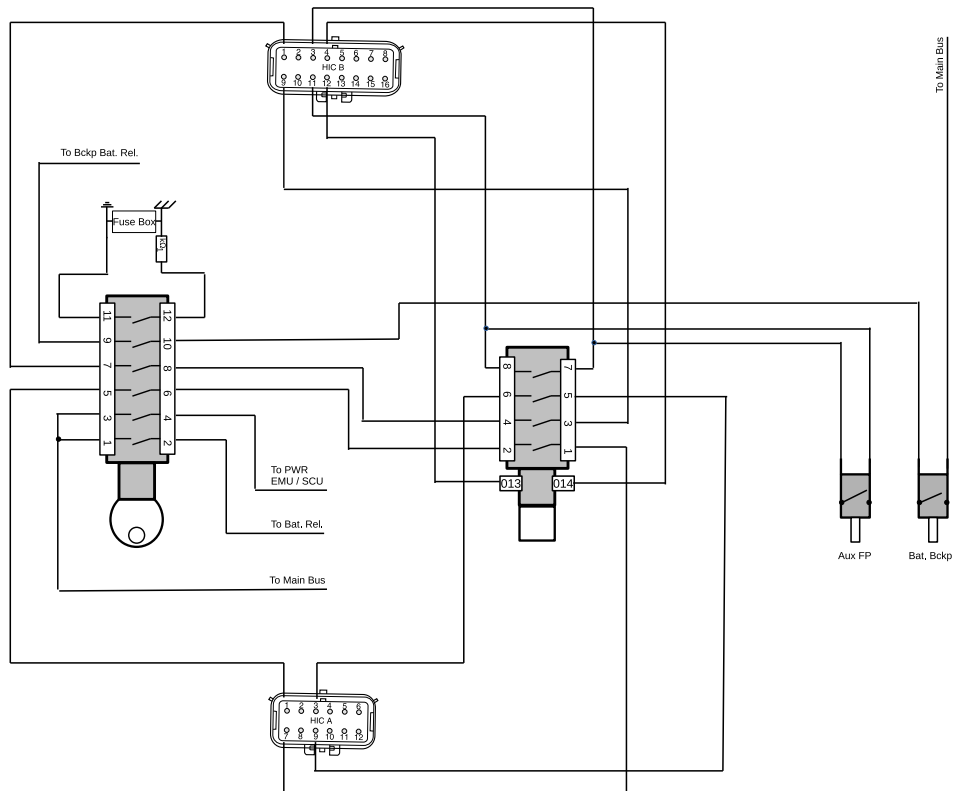

**Figure 4-1: iS Engine Panel V3 wiring diagram**

## 4.2 Electrical Installation standalone

In the standalone configuration, the iSEP covers the function of the start Power. The engine switch activates the start power in position “ENGINE POWER”. After engine start, the engine switch must be turned to position “BATTERY ON” in order deactivate the start power function. The pin out for the standalone configuration is shown in the following tables.

Pin Engine Switch	Connector	Pin	Signal Name	Signal Description	Current / Wire Size
1	-	-	BAT	BAT Supply	
2	-	-	BAT	BAT Signal	
3	Fuse Box X3	2	SP	Start Power	20 A
4	Fuse Box X3	3	SP	Start Power	20 A
5	-	-	GND	EMS GND	20 A
6	-	-	GND	Aircraft GND	20 A
7	-	-	-	-	-
8	-	-	-	-	-
9	-	-	-	-	-
10	-	-	-	-	-
11	-	-	GND	EMS GND	AWG 22
12	-	-	GND	Aircraft GND	AWG 22

**Table 4-3: Engine Switch (Key) pinout for standalone**

Pin Lane Switch	Connector	Pin	Signal Name	Signal Description	Current / Wire Size
1	HIC A	7	LANE_SEL_SW_A_2	Lane A Supply	7.5 A
2	Start Key Switch	6	LANE_SEL_SW	Lane A Signal	7.5 A
3	HIC B	9	LANE_SEL_SW_B_2	Lane B Supply	7.5 A
4	Start Key Switch	8	LANE_SEL_SW	Lane B Signal	7.5 A
5	HIC A	3	SIG_FUEL_PUMP_1	Fuel Pump Main Signal	10 A
6	HIC A	9	GND_FUEL_PUMP_1	Fuel Pump Main Supply	10 A
7	HIC B	11	GND_FUEL_PUMP_2	Fuel Pump AUX Supply	10 A
8	HIC B	3	SIG_FUEL_PUMP_2	Fuel Pump AUX Signal	10 A
013	HIC B	4	CONN_STARTER_REL_SW	Starter Signal	5 A
014	HIC B	12	SUPP_START_SWITCH	Starter Supply	5 A

**Table 4-4: Lane Switch (Knob) pinout for standalone**

The auxiliary fuel pump switch must be wired in parallel to Pin 7 and 8 of the Lane Switch

The “Battery Backup” Switch can be used to control a relay (backup battery relay) or with direct wiring to the battery and the EMS / AC ground.

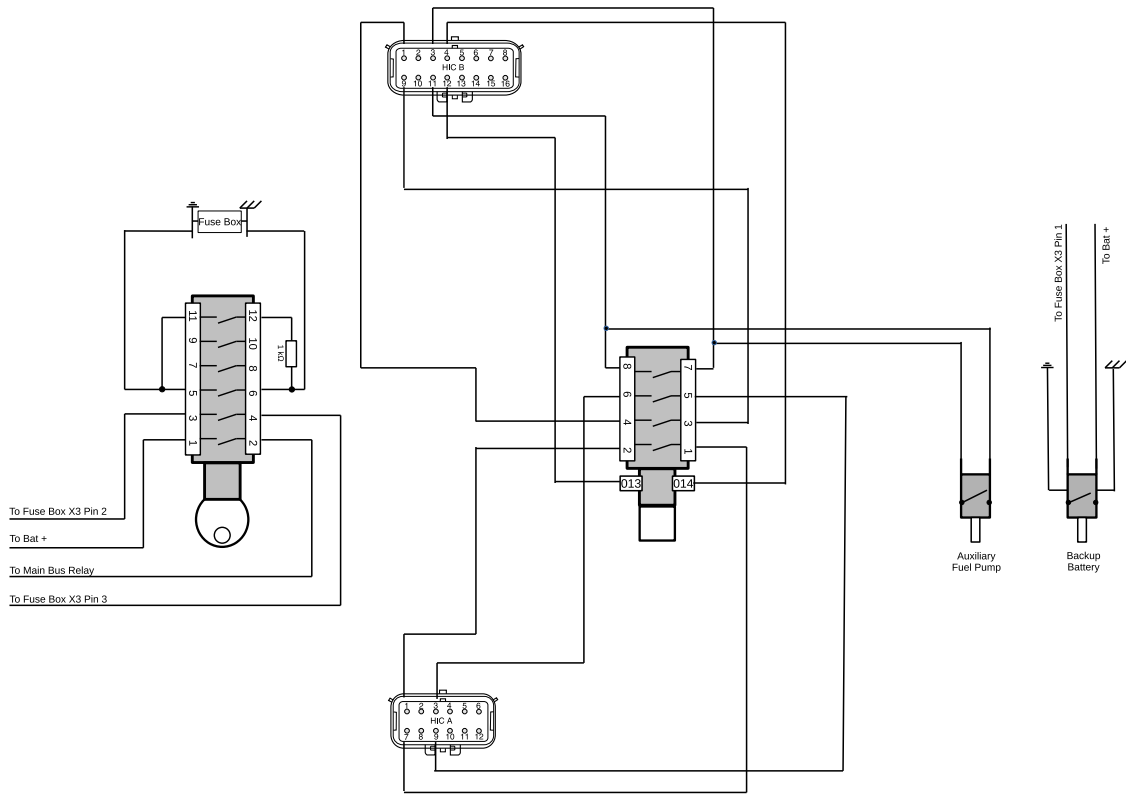

**Figure 4-2: iS Engine Panel V3 wiring diagram standalone variant**

## 5. Operation

This chapter describes operational procedures for the iS Engine Panel V3.

### 5.1 Operation with EMU (Variant 1)

- Engine Switch in “OFF” position: both grounds “Aircraft” and “EMS” are shorted to avoid different potentials during refueling and ground handling.
- Engine Switch in “BATTERY ON” position: The master relay is activated.
- Engine Switch in “ENGINE POWER” position: the SCU is powered. 1 sec later, the SCU activates the Start Power Relay and supplies the ECU with power. Also, the Backup Battery Switch is enabled in this position.
- Lane Switch in “LANE A” position: The ECU LANE A is activated, and the Main Fuel Pump is supplied with power.
- Lane Switch in “LANE A+B” position: The ECU LANE A and B are supplied with power, and the Main Fuel Pump is supplied with power. Hold this position for at least 1 sec. every time you pass it.
- Lane Switch in “LANE A+B” position pushed: The starter relay of the engine is activated. The “ENGINE START” position is spring loaded. After starting the engine, maintain in position “LANE A+B”. The Start Power Relay is automatically switched off by the SCU 3 sec. after the engine has reached 1500 rpm.
- Lane Switch in “LANE B” position: The ECU LANE B is supplied with power, and the Auxiliary Fuel Pump is supplied with power.
- The Auxiliary Fuel Pump can alternatively be switched on by switching the toggle switch “AUX FUEL PUMP” to “ON”.
- The Backup Battery function, if needed, can be utilized by switching the “BATTERY BACKUP” toggle switch to “ON”. This is only possible in “ENGINE POWER” position of the Engine Switch. (Optional. Only if backup Power is routed through Start Switch.)
- Both Lane A and Lane B can independently be switched off by turning either the Engine Switch or the Lane Switch to the “OFF” position. (Optional. Only if LANE activation is routed through Start Switch.)

Regarding the Lane check please refer to the Operators Manual by Rotax.



## 5.2 Operation standalone (Variant 2)

- Engine Switch in “OFF” position: both grounds “Aircraft” and “EMS” are shorted to avoid different potentials during refueling and ground handling.
- Engine Switch in “BATTERY ON” position: The master relay is activated.
- Engine Switch in “ENGINE POWER” position: the start power function of the iS engine is activated. EMS is supplied with power from battery.
- Lane Switch in “LANE A” position: The ECU LANE A is activated, and the Main Fuel Pump is supplied with power.
- Lane Switch in “LANE A+B” position: The ECU LANE A and B are supplied with power, and the Main Fuel Pump is supplied with power. Hold this position for at least 1 sec. every time you pass it.
- Lane Switch in “LANE A+B” position pushed: The starter relay of the engine is activated. The “ENGINE START” position is spring loaded. After starting the engine, maintain in position “LANE A+B”.
- Start Switch in “BATTERY ON” position: the start power function is deactivated. EMS is supplied with power from generator.
- Lane Switch in “LANE B” position: The ECU LANE B is supplied with power, and the Auxiliary Fuel Pump is supplied with power.
- The Auxiliary Fuel Pump can alternatively be switched on by switching the toggle switch “AUX FUEL PUMP” to “ON”.
- The Backup Battery function, if needed, can be utilized by switching the “BATTERY BACKUP” toggle switch to “ON”.

Regarding the Lane check please refer to the Operators Manual by Rotax.



RS Flight Systems GmbH

Oberer Luessbach 29-31

82335 Berg | Germany

+49 8178 8681 – 300

[contact@rs-flightsystems.com](mailto:contact@rs-flightsystems.com)

[www.rs-flightsystems.com](http://www.rs-flightsystems.com)

iS Engine Panel V3 | Version: 1.04

© Copyright 2024 RS Flight Systems GmbH